

rotameters



AALBORG



# Worldwide Distribution

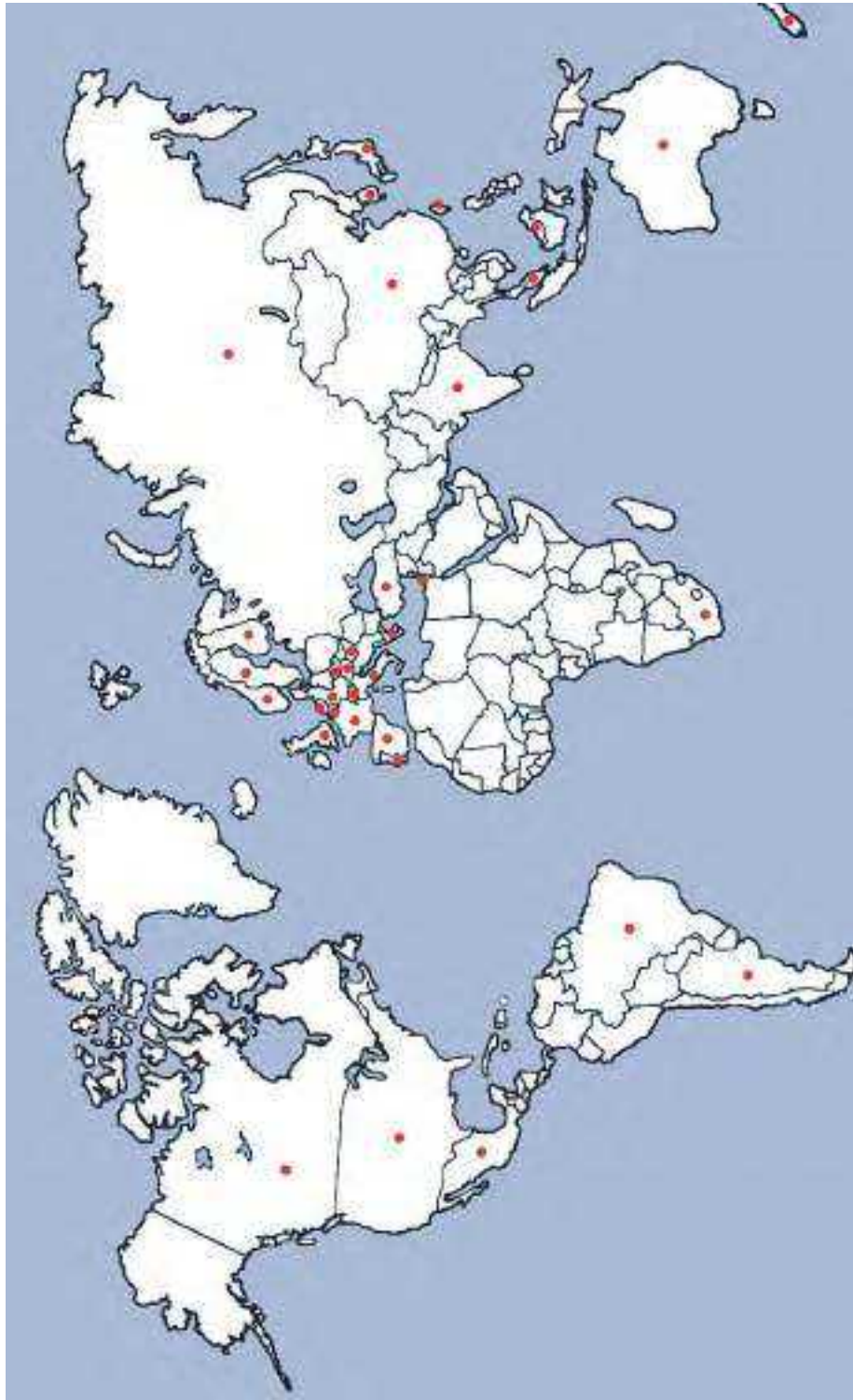

Visit our web site at: [aalborg.com](http://aalborg.com)

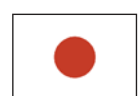



## About the Company

Founded in 1972, AALBORG® is well known throughout the world as a primary manufacturer of precision instrumentation for flow measurement and control.

### We operate two divisions:

**The Variable Area Division** manufactures a complete line of glass tube rotameters. These flow meters are available with aluminum, brass, stainless, steel or PTFE wetted components. AALBORG® also manufactures a unique line of PFA tube meters for ultrapure or corrosive applications. Precision barstock stainless steel or brass needle valves, as well as PTFE valves, are also manufactured in this division.

**The Electronics Division** produces analog and digital mass flow meters and controllers, as well as a diverse line of wafer and insertion type vortex flow meters for steam, liquid or gases. In addition, stepping motor driven valves made in this department are highly useful in processing and OEM applications.

## NIST Traceable

NIST traceable flow meter calibrations are performed in our state of the art laboratories.

## Technical Assistance

Technical Assistance is readily available. Customers are invited to contact the company or our distributors to discuss individual requirements. OEM applications are welcome.

## ISO9001 2000 Certification

AALBORG® has been ISO 9001 certified since April of 1995. We are very proud of the design features and the exceptionally high quality for which our products which have been known since 1972. It is our policy that through strict enforcement of exacting manufacturing standards the AALBORG® brand name continues to be associated with a reputation of high quality and reliability. Our products are backed by meticulous innovative engineering combined with efficient manufacturing practices and a highly skilled work force guaranteeing total customer satisfaction.

## Our Mission

It is the policy of AALBORG® to develop, produce and deliver products and services which consistently conform to or exceed customer requirements.

Our commitment is to provide cutting edge technology combined with a sincere desire to serve our customers and produce the highest quality products attainable.

# TABLE OF CONTENTS

Principle of Operation /General Description /Flow Tubes & Valves Pages 1-3

**CAL**

Calibrations

Page 4

**P**

**Px**

Single & Multiple Tube Flow Meters

Pages 5-9



**T**

**Tx**

PTFE-Glass Single and Multiple Tube Flow Meters

Pages 10-14



**S**

S Style Single Tube Flow Meters

Pages 15-17



**O**

Optical Sensor Switch

Pages 18-20



**G**

Gas Proportioners

Pages 21-23

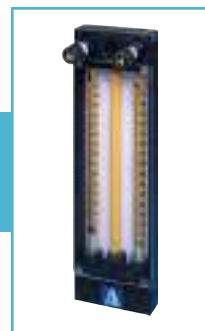

**K**

Kits

Page 24



**V** **xV**

Medium Range Brass, Stainless, PTFE and Direct Reader Flow Meters



Pages 25-29

**M**

Stainless Industrial Flow Meters



Pages 30-31

**F**

In Line PTFE Flow Meter



Page 32

**L**

PTFE-PFA Flow Meters



Pages 33-34

**VB**

Barstock Valves



Pages 35-36

**VT** **VT<sub>6</sub>**

PTFE Needle Valves



Pages 37-38

## TECHNICAL INFORMATION

Spare Valve Cartridge Flow Capacities	Page 40
Meter Sizing and Calculation vs Calibration	Page 41-42
Tables of Standard Flow Capacities	Pages 43-45
Table of Flow Capacities For Gas	Page 46
Direct Reading Scales	Pages 47-49
Conversion Factors	Page 50

## TRADEMARKS

*Lexan*<sup>®</sup> -is a registered trademark of General Electric Company.  
*Carboloy*<sup>®</sup> -is a registered trademark of General Electric Company.  
*Viton*<sup>®</sup> -is a registered trademark of DuPont Dow Elastomers.  
*Kalrez*<sup>®</sup> -is a registered trademark of DuPont Dow Elastomers.  
*Buna-N*<sup>®</sup> -is a registered trademark of DuPont Dow Elastomers.  
*Aalborg*<sup>®</sup> -is a registered trademark of Aalborg Instruments. Inc.  
*Kynar*<sup>®</sup> -is a registered trademark of Atochem North America, Inc.

*Aalborg*<sup>®</sup> reserves the right to change all designs and dimensions without notice.

For certified dimensions please contact *Aalborg*<sup>®</sup> Instruments and Controls.

# PRINCIPLE OF OPERATION

When compared with other types of flow instrumentation, variable area interchangeable flow meters offer the most practical, precise and economical means of visually indicating flow rate measurement.

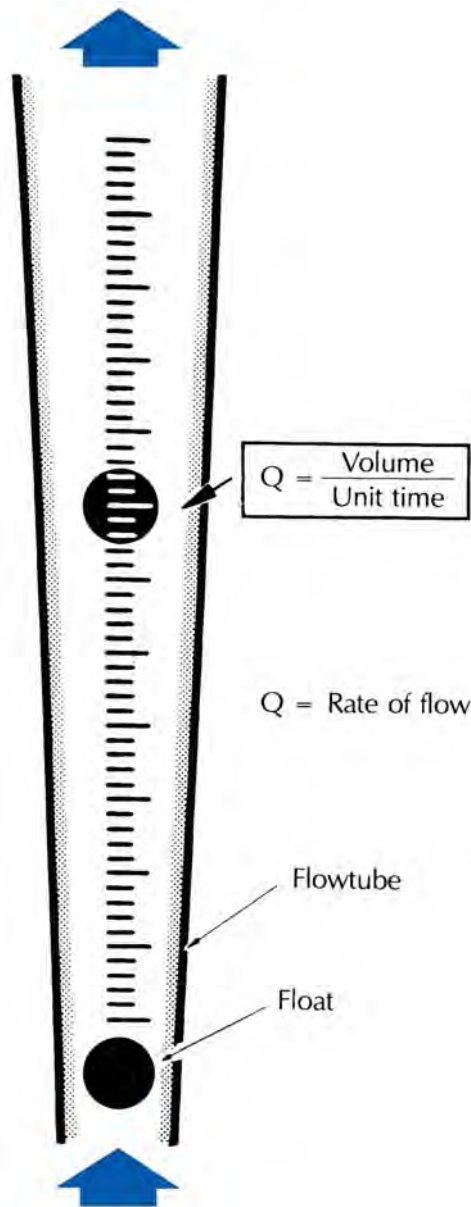

They require no electrical connections, and have low meter related pressure drops.

Meters are available in a large selection of flow rates and configurations, to accommodate the unique requirements of most applications.

Included in the line are flow tube assemblies, single and multiple tube flow meters. PTFE-Glass meters are for metering corrosive fluids or for high purity requirements.

Back pressure compensated Gas Proportioners are popular choices for blending component gases accurately to customized end use requirements at great savings.

Multiple tube flow meters are available with or without manifolding.

A tapered glass FLOW TUBE, and a spherical FLOAT inside it, constitute the heart of variable area type flow meters.

Flow meters are installed vertically in lines carrying gases or liquids to be monitored.

Fluids enter through the smaller opening at the bottom, and exit through the upper end. Upward pressure causes the float to rise. Flow takes place through the circular area between the float and the inside surface of the flow tube. As the float rises, the flow area increases, due to the tapered bore of the flow tube.

Dynamic equilibrium results when the buoyant force, due to the float and the upward force, due to fluid pressure, balance the weight of the float.

The vertical position of the float at equilibrium corresponds exclusively to one particular flow rate.

This flow rate is obtained by determining the height of the float with the aid of a scale etched on the flow tube.

These meters have the highest useful flow ranges providing consistently reliable readings from maximum flow down to 5 to 10% of capacity.

**INTERCHANGEABILITY**

Flow tubes and other components are thoroughly interchangeable resulting in greatly increased versatility. Meters are even interchangeable with standard sizes made by other manufacturers.

As a result of simple assembly and installation procedures, it is possible to use several sets of flow tubes in conjunction with one mounting frame.

**flow tubes**

- ✓ Precision fabricated from heavy walled, shock resistant borosilicate glass.
- ✓ Bores are uniformly tapered or formed with internal "rib-guides" or flutes.
- ✓ Floats are retained by TFE plugs.
- ✓ OPTIGRAD™ scales minimize parallax and eye fatigue.
- ✓ Interchangeability.
- ✓ Self cleaning.
- ✓ Low differential pressures that stay independent of Flow rate changes.

**OPTIGRAD™ SCALES**

The vertical "tangential locator line" facilitates hairline accuracy and convenience of reading. Flow tubes are supplied with millimeter, or direct reading scales.

Standard scale lengths are 65 mm (2.56 in) or 150mm (5.91 in). Flow rates are determined by lining up the scale graduation at the center of the spherical float.

Parallax and lack of visual reference will affect the accuracy and reproducibility of metering to a great extent. Such a drawback is eliminated by OPTIGRAD™ scales.

A vertical "locator" line is incorporated into the geometry of the scale graduation. To pinpoint the center of the float with "hairline" accuracy.

**readings are taken as follows:**

- 1) Position head in front of flow meter, with eyes at level with the float.
- 2) Move head horizontally to the left until the contour of the float appears to just touch the "locator" line tangentially.
- 3) The intersection of the "locator" line with the horizontal graduation at the center of the float, pinpoints the appropriate reading value.

**UNIVERSAL MILLIMETER SCALES**

Millimeter scales indicate the height to which the float rises within the metering tube and are correlated with specific flow rates through the use of appropriate calibration data sheets or curves.

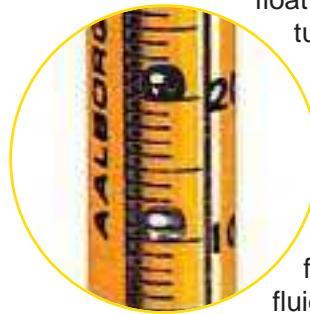

Scales of this type permit utilization of a given flow meter for a great number of different fluids at diverse pressure and temperature conditions. See tables 6,7,8, 9 and 10 on pages 43-46 for maximum flow rates.

To minimize eye fatigue associated with periods of repetitive readings, contrasting yellow backgrounds are provided behind scales

**DIRECT READING SCALES**

Direct reading scales are indicating flow rates, in engineering units such as [mL/min], standard cubic feet per hour [scfh] etc.

Such scales are designed exclusively for a specific gas or liquid at a given set of pressure and temperature and are valid for the associated units of flow only.

Thus, the convenience of direct reading scale designs should be weighed against the resultant limitations of applicability.

For listing of flow tubes with standard Direct Reading Scales, see tables 11-22 on pages 47 and 49.

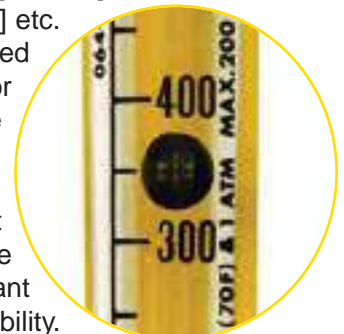

**BUILT-IN VALVES**

Meters are available with built-in needle valves (CV™), high precision metering valves (MFV™) with “non-rising stems”, or with no valves.

Built-in valves are mounted at the inlet (bottom) or outlet (top) of flow meters. Generally, for gas metering it is recommended that valves are positioned at inlets - for liquids valves may be positioned either at inlets or outlets. For vacuum service, valves must be mounted at outlets.

If unspecified at the time of ordering, meters will be shipped with valves mounted at the inlets.

**HIGH PRECISION VALVES (MFV™)**

The higher cost of MFV™ valves is justified whenever high sensitivity control and resolution are desirable particularly in conjunction with metering tubes of very low flow rates. A choice of six MFV™ flow capacities are offered (see Table 1 on page 40) to be matched with individual flow meter ranges.

This unique design comprises rectilinear motion valve needles, with non-rising stems. As the needle advances into and out of high precision cylindrical orifices, the flat tapered surface of the needle gradually, without turning, uncovers the flow area.

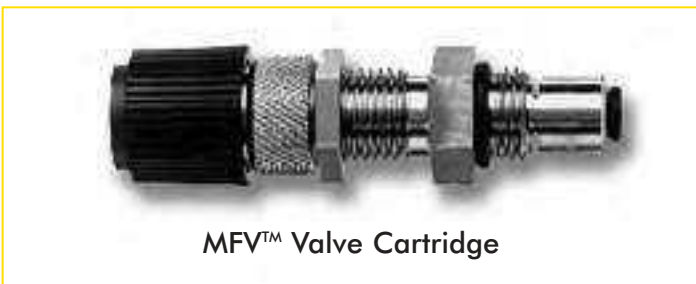

MFV™ Valve Cartridge

**CV™ VALVE CARTRIDGES**

These valves are designed for adjusting flow rates in applications where high resolution metering regulation is not essential. Available in three ranges, (see Table 2 on page 40) they represent a relatively inexpensive option.

The simple construction of CV™ valves incorporate a VALVE SPINDLE with conical ends and compound angles for optimal resolution.

The VALVE NEEDLE turns as it travels into or out of the VALVE ORIFICE. In conjunction with the cylindrical cross section, the conical front tip of the VALVE SPINDLE increases or decreases the annular flow area. The cartridge serves as a bubble-tight “shut-off” valve when the tip of the VALVE SPINDLE comes into a stop position against the VALVE ORIFICE.

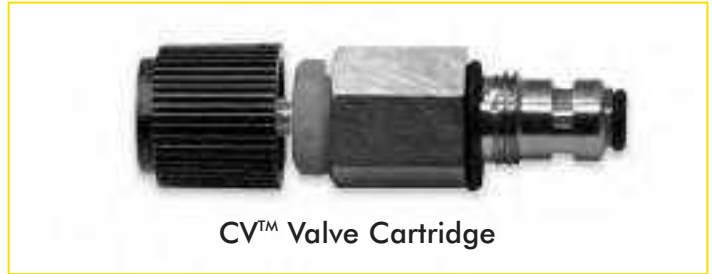

CV™ Valve Cartridge

**to reverse the position of valves**

- 1) Disassemble flow tubes from frames.
- 2) Install flow tubes upside down in frame.
- 3) Invert flow meter.



**FRONT SHIELDS WITH MAGNIFIER LENSES**

A unique longitudinal magnifier is part of the molded Lexan® front shield which is supplied on all single tube flow meters.

The magnification of the scale reading facilitates greatly enhanced resolution of measurement.

**MOUNTINGS**

Flow meters are shipped ready for panel mounting. Meters may be mounted on or behind panels.

For “on-panel” installations holes are drilled for inlet and outlet fittings and meters are mounted simply by means of panel mounting nuts supplied.

Mounting behind panels is done by utilizing the screws from front shields. Panel mounting is easily converted to self standing bench mounting by using the appropriate optional acrylic tripod base.



## NIST CALIBRATIONS

Our laboratories are fully equipped to perform NIST traceable flow calibrations for Rotameters, Mass Flow instruments and many other flow products.

We also offer calibration service on equipment and instrumentation of other manufactures products which are comparable to those manufactured by Aalborg®.

- ✓ Calibrations are performed at standard (STP) conditions (70°F/21.1 °C and 14.7 psia/1 atm abs).
- ✓ Gas calibrations for up to 2000 L/min and water calibrations up to 4 L/min available.
- ✓ Calibrated to NIST traceable standards.
- ✓ State-of-the-art Precision Glass-Piston, and Bell Prover type calibrations.

## PRESSURE LIMITS OF CALIBRATIONS

Up to 500 PSIG for routine gases (Air, N<sub>2</sub>, He, CO<sub>2</sub>, Ar and O<sub>2</sub>) with a maximum flow of 250 L/min. Up to 80 PSIG for Air, with a maximum flow of 1000 L/min.

### European Service Facility



Authorized repair and service facility for AALBORG® Thermal Mass Flow Systems and Rotameter Products. Calibrated to NMI (Netherlands Metering Institute) standards.

# AALBORG - ANALYT-MTC

MESSTECHNIK GMBH

Klosterrunsstraße 18 P.O. Box 1321

Müllheim D-79379 Germany

TELEFON: +49 (07) 631.5545

FAX: +49 (07) 631.14740

INTERNET: WWW.ANALYT-MTC.de

E-MAIL: info@analyt\_mtc.de



Typical Bell Prover used for NIST traceable calibrations

**INTERCHANGEABLE**

Designed for low flow rates, the **Model P** flow meter is a precision instrument embodying the inherent simplicity, versatility and economy of the classical rotameter. It is particularly suitable for metering carrier gases in chromatography, indicating and controlling gases in manufacturing processes, liquid and gas measurement in laboratories, pilot plants, flow and level indicating, etc.

Shipped completely assembled, flow meters include standard mounting fittings in a choice of materials, side plates, thick protective magnifying front shield and back plate, optional built-in control valve, and flow tubes selected from the Flow Capacities tables. Panel mounting style is convertible to bench mounting through the use of the optional acrylic tripod. The tripod has a built-in spirit leveler and leveling screws.

For multiple tube meters see pages 7 and 8.

**design features**

- ✓ Rib-guided or fluted metering tubes facilitate stable, accurate readings.
- ✓ Magnifier lens in front shield to enhance reading resolution.
- ✓ Interchangeability of flow tubes and floats.
- ✓ Ease of installation and exchange of flow tubes.
- ✓ "Non-rotating" adapter feature - glass flow tubes are prevented from turning during the tightening phase of the assembly procedure.
- ✓ OPTIGRAD™ scales minimize parallax and eye fatigue.
- ✓ Chemical compatibility.
- ✓ Simple means of panel mounting.

150 mm Meter with CV™ Valve



65 mm Meter with MFV™ Valve

## BUILT-IN VALVES

Meters are available with built-in needle valves (CV™), high precision metering valves (MFV™) with “non-rising stems”, or with no valves. The higher cost of MFV™ valves is justified whenever high sensitivity control and resolution are desirable particularly in conjunction with metering tubes of very low flow rates.

Generally, for gas metering it is recommended that valves are positioned at inlets (bottom) for liquids valves may be positioned either at inlets or outlets (top). For vacuum services, valves must be mounted at outlets. If unspecified at the time of ordering, meters will be shipped with valves mounted at the inlets.

Panel mounting is convertible to bench mounting through the use of an optional acrylic tripod base with spirit leveler (catalog No. TP1).

SPECIFICATIONS	
<b>STANDARD ACCURACY</b>	±2% FS mm scales except 042 flow tubes. ±5% FS direct reading scales and 042 flow tubes.
<b>CALIBRATED ACCURACY</b>	±1% FS optional.
<b>REPEATABILITY</b>	±0.25%.
<b>USEFUL FLOW RANGE</b>	10:1 minimum with one float and better than 20:1 with combination of two floats installed in meters.
<b>MAXIMUM OPERATING PRESSURE</b>	200 psig/13.8 bars.
<b>MAXIMUM OPERATING TEMPERATURE</b>	250 °F/ 121 °C.

**MATERIALS OF CONSTRUCTION	
<b>FLOW TUBES</b>	Heavy walled borosilicate glass.
<b>FLOATS</b>	Glass, Sapphire, 316 Stainless Steel, Carboloy® and Tantalum.
<b>CHOICE OF MOUNTING FITTINGS IN CONTACT WITH FLUIDS</b>	a) Aluminum, black anodized. b) Brass, chrome plated. c) 316 stainless steel.
<b>SIDE PANELS</b>	Aluminum, black anodized.
<b>FRONT SHIELD</b>	Lexan® with longitudinal magnifier lens for enhanced reading resolution.
<b>BACK PLATE</b>	1/8" thick white acrylics.
<b>O-RINGS AND PACKING</b>	Buna-N® o-rings in aluminum/ brass model. Viton® o-rings in stainless steel meters. <b>OPTIONAL</b> Viton® PTFE Kalrez® and EPR.
<b>CONNECTIONS</b>	1/8" NPT female inlet and outlet connections. <b>OPTIONAL</b> 1/4" FNPT, hose and compression fittings are available.

Select flow tube consistent with requirements from flow capacity tables 6 to 22 (page 43 to 49).

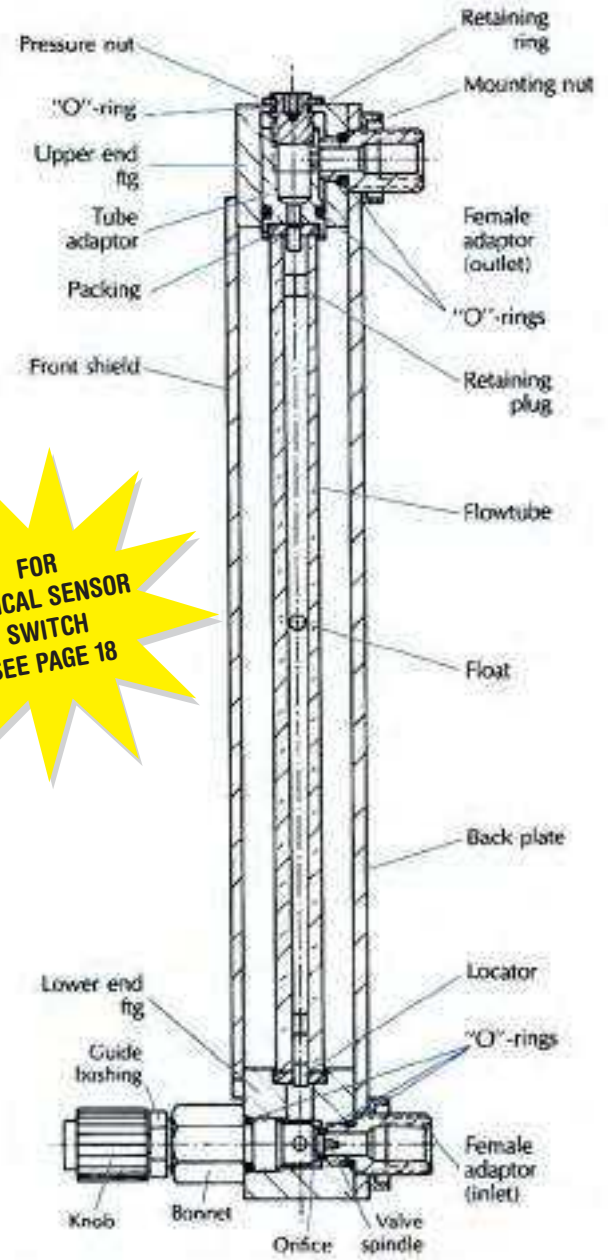

Assorted flow tubes may be used in conjunction with a single mounting frame, an apparent benefit in many laboratory applications.

**Ordering information see page 9.**  
**Dimensional information see page 8.**

\*\*The selection of materials of construction, is the responsibility of the customer. The company accepts no liability.

The **Model Px** multiple tube flow meter line offers, the convenience and simplicity of 2, 3, 4, 5 and 6 tube meters, retaining most of the unique design features associated with single tube units. Multiple tube meters are available with 65mm or 150mm flow tubes same as used in single unit flow meters.

**Px meters are convenient for applications where several streams of gases or liquids are to be metered in individual channels, or manifolded.**

Shipped completely assembled, flow meters include standard mounting fittings in a choice of materials, side plates, thick protective front shield and back plate, optional built-in control valve, and flow tubes selected from the Flow Capacities tables.

Panel mounting style is convertible to bench mounting through the use of the optional acrylic tripod. The tripod has a built-in spirit leveler and leveling screws.

## design features

- ✓ Rib-guided or fluted metering tubes facilitate stable, accurate readings.
- ✓ Interchangeability of flow tubes and floats.
- ✓ Manifolding at inlet or outlet.
- ✓ Ease of installation and exchange of flow tubes.
- ✓ "Non-rotating" adapter feature - glass flow tubes are prevented from turning during the tightening phase of the assembly procedure.
- ✓ OPTIGRAD™ scales minimize parallax and eye fatigue.
- ✓ Chemical compatibility.
- ✓ Simple means of panel mounting.

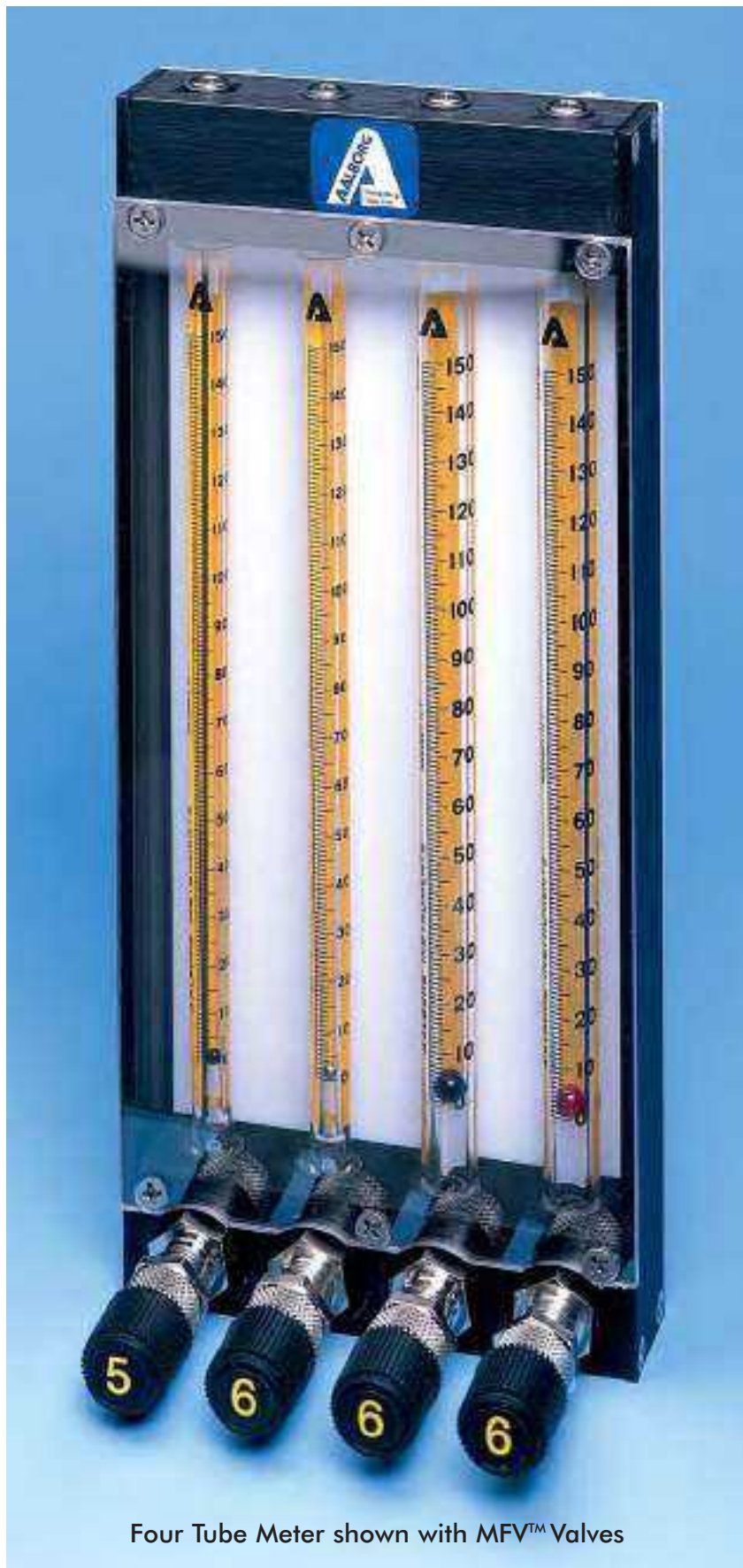

Four Tube Meter shown with MFV™ Valves



## BUILT-IN VALVES

Meters may be supplied with built-in needle valves (CV™), high precision metering valves (MFV™) with “non-rising stems”, or with no valves. Generally for gas metering, it is recommended that valves are positioned at inlets (bottom) for liquids valves may be positioned either at outlets (top) or inlets. For vacuum service, valves must be mounted at outlets. If unspecified at the time of ordering, meters will be shipped with valves mounted at inlets.

## MOUNTING DIMENSIONS

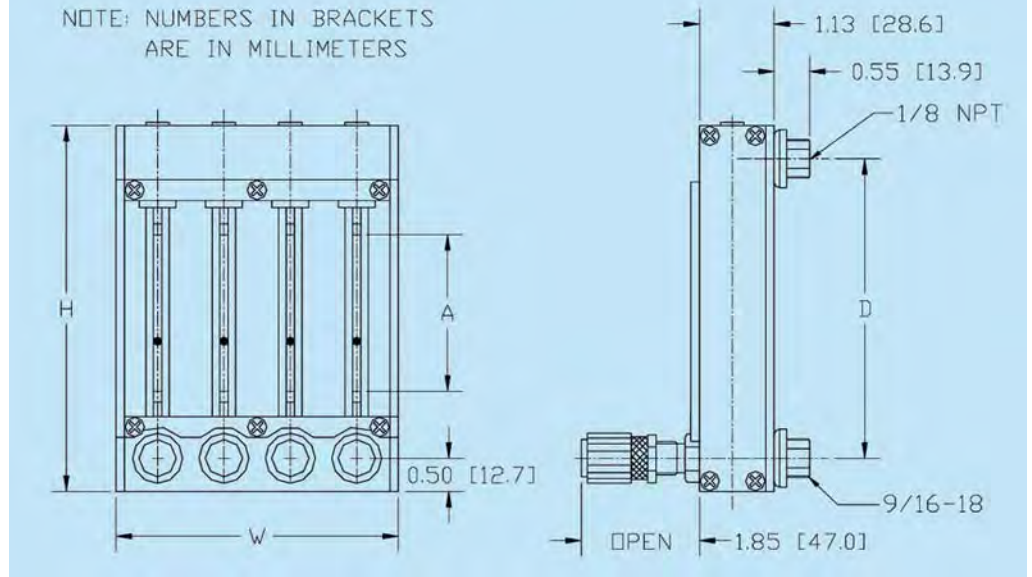

## SPECIFICATIONS

### STANDARD ACCURACY

±2% FS mm scales except 042 flow tubes.  
 ±5% FS direct reading scales and 042 flow tubes.  
 Conforming to ISA RP. 16-1.2.3 Specification 2-S-10. Manifoldd models excepted.

### CALIBRATED ACCURACY

±1% FS optional.

### REPEATABILITY ± 0.25%

### USEFUL FLOW RANGES

10:1 minimum with one float. Better than 20:1 with combinations of two floats installed in meters.

### MAXIMUM OPERATING PRESSURE

200 psig /13.8 bars.

### MAXIMUM OPERATING TEMPERATURE

250 °F /121 °C.

## \*\*MATERIALS OF CONSTRUCTION

**FLOW TUBES** Heavy walled borosilicate glass.

### CHOICE OF MOUNTING FITTINGS IN CONTACT WITH FLUIDS

- a) Aluminum, black anodized.
- b) 316 Stainless Steel.

**SIDE PANELS** Aluminum, black anodized.

### FRONT SHIELD AND BACK PLATE

1/8" thick clear polycarbonate and white acrylics.

### O-RINGS AND PACKING

Buna-N® o-rings in aluminum model.  
 Viton® o-rings in stainless steel meters.  
**OPTIONAL** Viton®, PTFE/Kalrez®, EPR.

**CONNECTIONS** 1/8" NPT female inlet and outlet connections.

**OPTIONAL:** 1/4" FNPT, hose & compression fittings are available.

Ordering information see page 9.

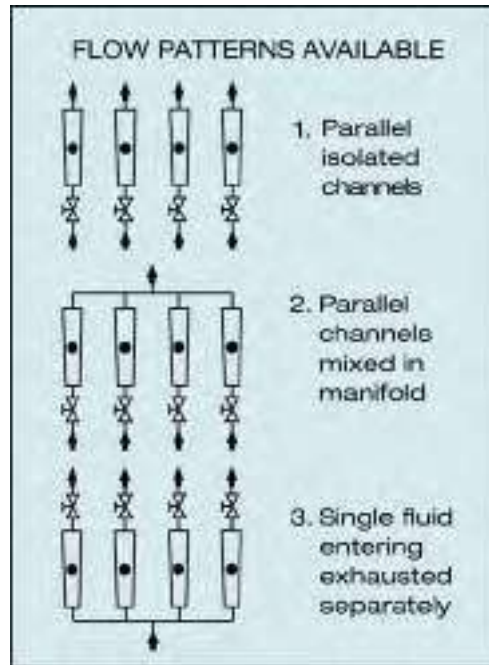

The built-in-valves are always installed in the end block opposite to the manifolded one.

Thus, if a meter is manifolded at the outlet, valves are installed at the inlets; if a meter is manifolded at the inlet, valves are installed at the outlets.

## DIMENSIONS FOR P STYLE METERS

SCALE LENGTH (A)	ALL P METERS		WIDTH (W)					
	HEIGHT (H)	CENTER TO CENTER (D)	1 TUBE	2 TUBE	3 TUBE	4 TUBE	5 TUBE	6 TUBE
65mm	5.500	4.500	1.250	2.250	3.250	4.250	5.250	6.250
150mm	9.813	8.813	1.250	2.250	3.250	4.250	5.250	6.250



## GENERAL DESCRIPTION

**Model T** flow meters incorporate the principles of traditional variable area flow technology.

**These rugged PTFE-Glass flow meters offer solutions to low to medium flow range measurements of highly corrosive or ultra-pure liquids and gases.**

Wetted inert components are surrounded by structurally rigid anodized aluminum. The resultant design represents a unique combination of a rugged mechanically rigid frame and chemically inert wetted parts.

For additional protection of personnel each meter is supplied with a thick protective magnifying safety shield.

\*Glass and Sapphire floats are recommended.

### design features

- ✓ Constructed of inert materials: Borosilicate Glass, PTFE and PCTFE.
- ✓ Chemically inert wetted parts within mechanically rigid frame.
- ✓ Rib-guided or fluted metering tubes facilitate stable, accurate readings.
- ✓ Magnifier lens in front shield to enhance reading resolution.
- ✓ OPTIGRAD™ scales minimize parallax and eye fatigue.
- ✓ Simple means of panel mounting.
- ✓ Interchangeability of flow tubes and floats.
- ✓ Conveniently overlapping flow ranges available in both standard millimeter and "direct reading" scales.



# T

# PTFE-SINGLE GLASS FLOW METERS

## LEAK INTEGRITY

Flow meters are individually tested on a Mass Spectrometer Leak Detector and certified to a leak integrity rating of  $1 \times 10^{-7}$  sccs Helium or better.

## BUILT-IN VALVES

Meters are available with built-in needle valves (CVT™), high precision metering valves (MVT™) with “non-rising stems”, or with no valves. The higher cost of MVT™ valves is justified whenever high sensitivity control and resolution are desirable particularly in conjunction with metering tubes of very low flow rates.

When meters with valves are ordered the valve cartridges are installed at the inlet. For vacuum service it is recommended that meters are ordered with valves at the outlet.

Assorted flow tubes may be used in conjunction with a single mounting frame, an apparent benefit in many laboratory applications.

## SPECIFICATIONS

<b>STANDARD ACCURACY</b>	±2% FS mm scales except 042 flow tubes. ±5% FS direct reading scales and 042 flow tubes.
<b>REPEATABILITY</b>	± 0.25%.
<b>USEFUL FLOW RANGES</b>	10:1 minimum with one float.
<b>MAXIMUM OPERATING PRESSURE</b>	100 psig/6.7 bars.
<b>MAXIMUM OPERATING TEMPERATURE</b>	150 °F/ 65 °C.
<b>LEAK INTEGRITY</b>	Individually pressure and leak tested and certified to a rating of $1 \times 10^{-7}$ sccs Helium.

## \*\*MATERIALS OF CONSTRUCTION

<b>FLOW TUBES</b>	Heavy walled borosilicate glass. (Sapphire or glass floats recommended).
<b>FITTINGS IN CONTACT WITH FLUIDS</b>	Virgin PTFE PCTFE.
<b>SIDE PLATES</b>	Aluminum, black anodized.
<b>FRONT SHIELD AND BACK PLATE</b>	1/8" thick clear polycarbonate and white acrylics.
<b>O-RINGS</b>	PTFE.
<b>CONNECTIONS</b>	1/8" NPT female inlet and outlet connections.
<b>OPTIONAL</b>	glass hose nipples or compression fittings.

\*\*The selection of materials of construction, is the responsibility of the customer. The company accepts no liability.

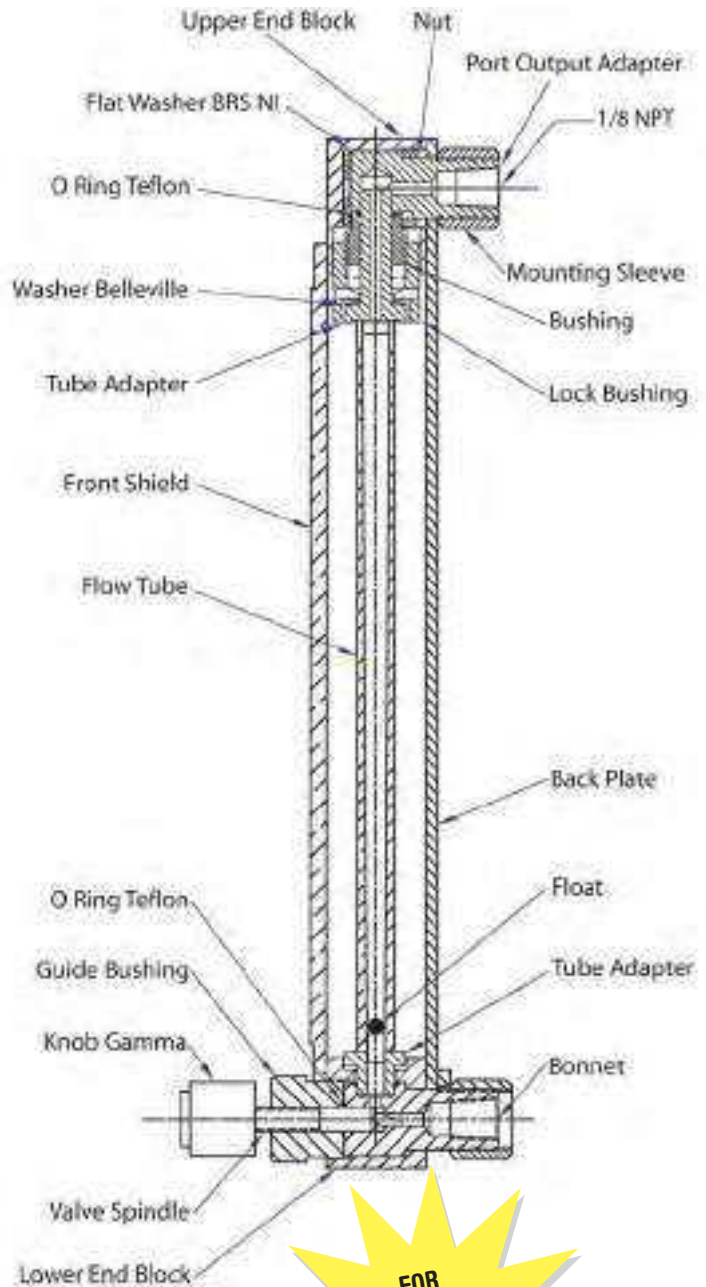

**FOR  
OPTICAL SENSOR  
SWITCH  
SEE PAGE 18**

Panel mounting is convertible to bench mounting through the use of an optional acrylic tripod base with spirit leveler (catalog No. TP1).

**Ordering information see page 14.  
Dimensional information see page 13.**



*Model Tx* Multiple Tube PTFE-Glass Flow meters combine the convenience of multiple tube meters with the unique design features of single tube PTFE-Glass flow meters. These meters are available with the same interchangeable 65mm or 150mm glass flow tubes used in single tube designs and they are available with or without built-in PTFE needle valves.

Wetted inert components are surrounded by structurally rigid anodized aluminum. The resultant design represents a unique combination of a rugged mechanically rigid frame and chemically inert wetted parts.

**They are ideal for applications where several streams of corrosive gases or liquids are to be metered in individual channels or as a controlled mixer in manifolded models.**

## design features

- ✓ Constructed of inert materials: Borosilicate Glass, PTFE and PCTFE.
- ✓ Chemical inert wetted parts within mechanically rigid frame.
- ✓ Rib-guided or fluted metering tubes facilitate: stable, accurate readings.
- ✓ OPTIGRAD™ scales minimize parallax and eye fatigue.
- ✓ Simple means of panel mounting.
- ✓ Interchangeability of flow tubes and floats.
- ✓ Conveniently overlapping flow ranges available in both standard millimeter and direct reading scales.

Four Tube PTFE meter shown with CVT™ valves





# MULTIPLE TUBE-PTFE GLASS FLOW METERS

## BUILT-IN VALVES

Meters are available with built-in needle valves (CVT™), high precision metering valves (MVT™) with non-rising stems, or with no valves. The higher cost of MVT™ valves is justified whenever high sensitivity control and resolution are desirable particularly in conjunction with metering tubes of very low flow rates.

**For vacuum service it is recommended that meters are ordered with valves at the outlet.**

## DIMENSIONS

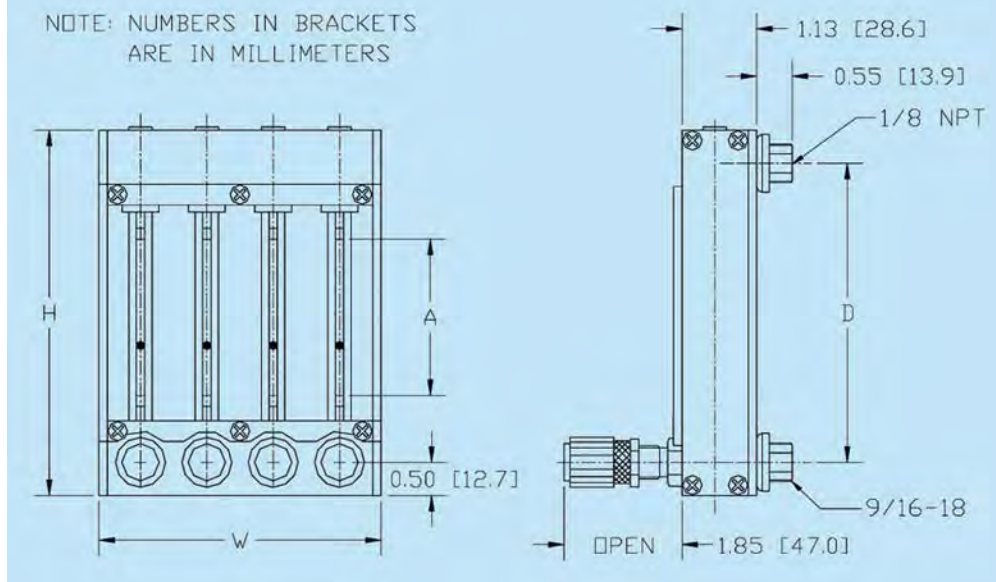

## LEAK INTEGRITY

Flow meters are individually tested on a Mass Spectrometer Leak Detector and certified to a leak integrity rating of  $1 \times 10^{-7}$  sccs Helium or better.

Note: To obtain millimeters multiply inch dimensions by 2.54.

## SPECIFICATIONS

<b>STANDARD ACCURACY</b>	$\pm 2\%$ FS mm scales except 042 flow tubes. $\pm 5\%$ FS direct reading scales and 042 flow tubes.
<b>REPEATABILITY</b>	$\pm 0.25\%$ .
<b>USEFUL FLOW RANGES</b>	10:1 minimum with one float.
<b>MAXIMUM OPERATING PRESSURE</b>	100 psig /6.7 bars.
<b>MAXIMUM OPERATING TEMPERATURE</b>	150 °F / 65 °C.
<b>LEAK INTEGRITY</b>	Individually pressure and leak tested and certified to a rating of $1 \times 10^{-7}$ sccs Helium.

## \*\*MATERIALS OF CONSTRUCTION

<b>FLOW TUBES</b>	Heavy walled borosilicate glass. (Sapphire or glass floats recommended).
<b>FITTINGS IN CONTACT WITH FLUIDS</b>	Virgin PTFE PCTFE.
<b>SIDE PANELS</b>	Aluminum, black anodized.
<b>FRONT SHIELD AND BACK PLATE</b>	1/8" thick clear polycarbonate and white acrylics.
<b>O-RINGS</b>	PTFE.
<b>CONNECTIONS</b>	1/8" NPT female inlet and outlet connections.
<b>OPTIONAL</b>	glass hose nipples or compression fittings.

\*The selection of materials of construction, is the responsibility of the customer. The company accepts no liability.

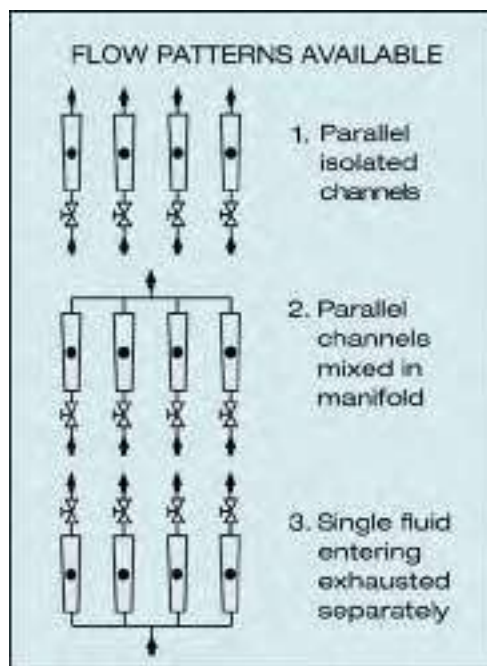

**When meters with valves are ordered the valve cartridges are installed at the inlet.**

## DIMENSIONS FOR T STYLE METERS

SCALE LENGTH (A)	ALL METERS		WIDTH (W)			
	HEIGHT (H)	CENTER TO CENTER (D)	TUBE 1	TUBE 2	TUBE 3	TUBE 4
65mm	6.156	5.156	1.250	2.250	3.250	4.250
150mm	10.46	9.469	1.250	2.250	3.250	4.250

BULLETIN EM201007 TX



## EXAMPLE

<b>T</b>	T STYLE METERS						
<b>CODE</b>	NUMBER OF CHANNELS						
<b>1</b>	SINGLE CHANNEL (ONE TUBE)						
<b>2</b>	TWO CHANNEL METER (TWO TUBES)						
<b>3</b>	THREE CHANNEL METER (THREE TUBES)						
<b>4</b>	FOUR CHANNEL METER (FOUR TUBES)						
<b>CODE</b>	SIZE						
<b>6</b>	65 mm						
<b>1</b>	150 mm						
<b>CODE</b>	MATERIAL						
<b>T</b>	PTFE						
<b>CODE</b>	VALVE POSITION						
<b>1</b>	MVT (HIGH PRECISION) INLET						
<b>3</b>	NO VALVE						
<b>4</b>	CVT (STANDARD CARTRIDGE) INLET						
<b>5</b>	MVT (HIGH PRECISION) OUTLET						
<b>6</b>	CVT (STANDARD CARTRIDGE) OUTLET						
<b>CODE</b>	SEALS						
<b>T</b>	PTFE						
<b>CODE</b>	FITTINGS						
<b>A</b>	1/8" FNPT (STANDARD)						
<b>F</b>	1/4" COMPRESSION						
<b>G</b>	GLASS NIPPLE						
<b>CODE</b>	MANIFOLD						
<b>0</b>	NONE (STANDARD FOR SINGLE CHANNEL)						
<b>1</b>	BOTTOM						
<b>2</b>	TOP						

<b>T</b>					—				—	<b>TUBE</b>
----------	--	--	--	--	---	--	--	--	---	-------------

**Optional Accessories**

**TP1**-Tripod for single channel meter.  
**TP2**-Tripod for 2 and 4 isolated channels or manifolding at top.  
**TP3**-Tripod for 3 isolated channels or manifolding at bottom.  
**TP5**-Tripod for 3 single tube meters.

**Select tube from the following tables:**

Tables 6 to 22. Pages 43 to 49.

# S

## SINGLE TUBE FLOW METERS

### S STYLE

*Model S* single-tube flow meters pictured on this page are similar to *P* meters in design, employing the same interchangeable flow tubes, valves, and accessories. Likewise they may be panel or bench mounted.

Model S Flow Meter Shown.  
With Optional Tripod Base and CV™ Valve



FOR  
OPTICAL SENSOR  
SWITCH  
SEE PAGE 18

The important advantage of the *S* meter is convenience in applications, where frequent changing of tubes in meter cases is desired.

An example is when several flow tubes are used in conjunction with a single meter case, or when because of the nature of the fluid, periodic cleaning necessitates disassembly.

Aalborg's® exclusive TUBELOK™ design facilitates simple installation and replacement of tubes in mounting cases.

As a result of the “non-rotating” adapter feature, glass flow tubes are prevented from turning during the tightening phase of the assembly procedure.

### design features

- ✓ TUBELOK™ design simplifies installation and replacement of tubes.
- ✓ Rib-guided or fluted metering tubes facilitate stable, accurate readings.
- ✓ Magnifier lens in front shield to enhance reading resolution.
- ✓ OPTIGRAD™ scales minimize parallax and eye fatigue.
- ✓ Simple means of panel mounting.
- ✓ Interchangeable flow tubes and floats.



## BUILT-IN VALVES

Meters are available with built-in needle valves (CV™), high precision metering valves (MFV™) with “non-rising stems”, or with no valves. The higher cost of MFV™ valves is justified whenever high sensitivity control and resolution are desirable particularly in conjunction with metering tubes of very low flow rates. Generally, for gas metering it is recommended that valves are positioned at inlets (bottom) for liquids valves may be positioned either at inlets or outlets (top). For vacuum services, valves must be mounted at outlets. If unspecified at the time of ordering, meters will be shipped with valves mounted at the inlets.

SPECIFICATIONS	
<b>STANDARD ACCURACY</b>	±2% FS mm scales except 042 flow tubes. ±5% FS direct reading scales and 042 flow tubes.
<b>CALIBRATED ACCURACY</b>	±1% FS optional.
<b>REPEATABILITY</b>	±0.25%.
<b>USEFUL FLOW RANGE</b>	10:1 minimum with one float. Better than 20:1 with combination of two floats installed in meters.
<b>MAXIMUM OPERATING PRESSURE</b>	200 psig/13.8 bars.
<b>MAXIMUM OPERATING TEMPERATURE</b>	250 °F/ 121 °C.

**MATERIALS OF CONSTRUCTION	
<b>FLOW TUBES</b>	Heavy walled borosilicate glass.
<b>FLOATS</b>	Glass, Sapphire, 316 Stainless Steel, Carboloy® and Tantalum.
<b>CHOICE OF MOUNTING FITTINGS IN CONTACT WITH FLUIDS</b>	a) Aluminum, black anodized. b) Brass, chrome plated. c) 316 stainless steel.
<b>SIDE PANELS</b>	Aluminum, black anodized.
<b>FRONT SHIELD</b>	Lexan® with longitudinal magnifier lens for enhanced reading resolution.
<b>BACK PLATE</b>	1/8" thick white acrylics.
<b>O-RINGS AND PACKING</b>	Buna-N® o-rings in aluminum model. Viton® o-rings in stainless steel meters. <b>OPTIONAL</b> Viton®, PTFE/Kalrez® and EPR.
<b>CONNECTIONS</b>	1/8" NPT female inlet and outlet connections.
<b>OPTIONAL</b>	1/4" FNPT, hose and compression fittings are available.

\*\*The selection of materials of construction, is the responsibility of the customer. The company accepts no liability.

DIMENSIONS FOR S STYLE METERS		
SCALE LENGTH (A)	ALL METERS	
	HEIGHT (H)	CENTER TO CENTER (D)
65mm	6.156	5.156
150mm	10.46	9.469

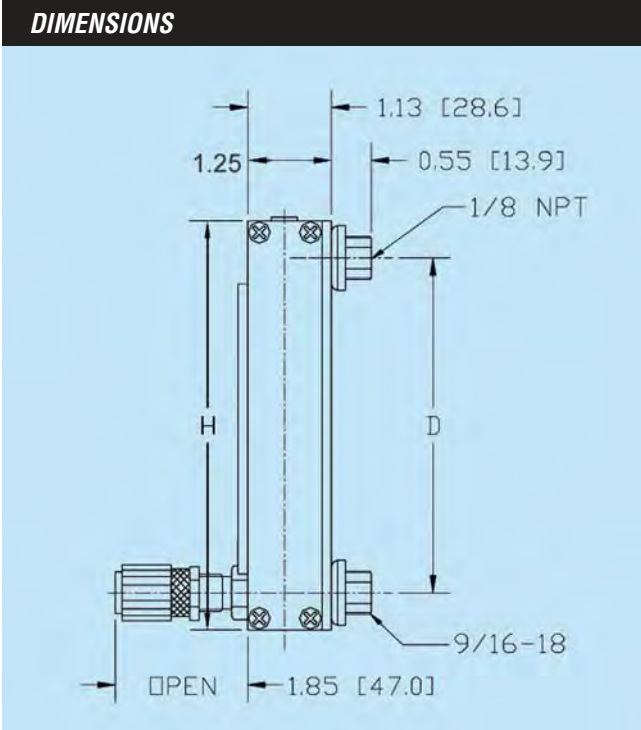
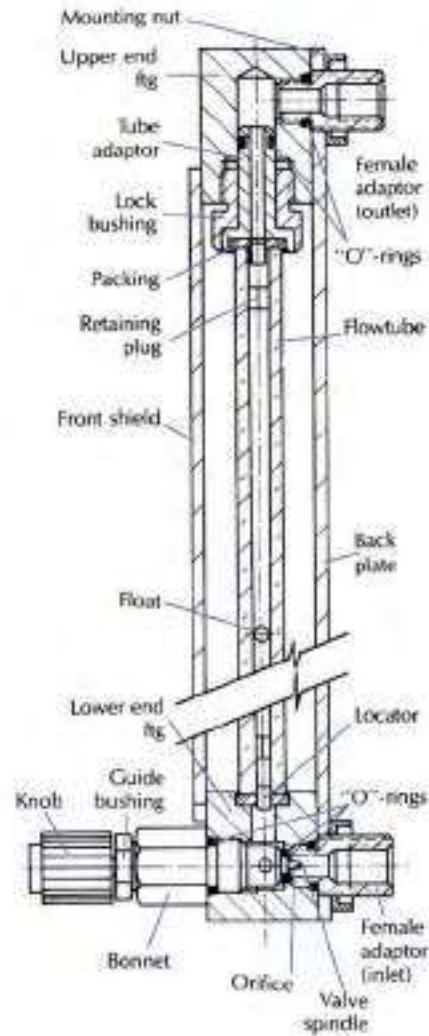



# ORDERING INFORMATION MODEL S METERS

## EXAMPLE

<b>S</b>	S STYLE METERS	
<b>CODE</b>	NUMBER OF CHANNELS	
<b>1</b>	SINGLE CHANNEL (ONE TUBE)	
<b>CODE</b>	SIZE	
<b>6</b>	65 mm	
<b>1</b>	150 mm	
<b>CODE</b>	MATERIAL	
<b>A</b>	ALUMINUM	
<b>B</b>	BRASS	
<b>S</b>	STAINLESS STEEL	
<b>CODE</b>	VALVE POSITION	
<b>1</b>	MFV (HIGH PRECISION) INLET	
<b>3</b>	NO VALVE	
<b>4</b>	CV (STANDARD CARTRIDGE) INLET	
<b>5</b>	MFV (HIGH PRECISION) OUTLET	
<b>6</b>	CV (STANDARD CARTRIDGE) OUTLET	
<b>CODE</b>	SEALS	
<b>V</b>	VITON® STD ON STAINLESS METERS	
<b>B</b>	BUNA® STD ON BRASS AND ALUMINUM	
<b>E</b>	EPR	
<b>T</b>	PTFE/KALREZ®	
<b>CODE</b>	FITTINGS	
<b>A</b>	1/8" FNPT	
<b>B</b>	1/4" FNPT	
<b>C</b>	1/8" HOSE NIPPLE	
<b>D</b>	1/4" HOSE NIPPLE	
<b>E</b>	1/8" COMPRESSION	
<b>F</b>	1/4" COMPRESSION	
<b>H</b>	WCR	
<b>CODE</b>	FITTINGS	
<b>0</b>	NONE	
<b>S</b>		<b>TUBE</b>

### Optional Accessories

TP1-Tripod for single channel meter.

### Select tube from the following tables:

Tables 6 to 22. Pages 43 to 49.

## GENERAL DESCRIPTION

The **Optical Sensor Switch** is a noninvasive means for detection of a HI or LOW flow. This sensor is ideal for signaling an alarm, cutoff valve, or other device when the float passes the detector (alarm, valve etc. not included). Helps protect your processes and equipment from damage caused by extreme flow rates.

It's compact design and ease of operation make it a nonobtrusive simple to use addition to your flow meter. Perfect for OEM applications. Use whenever maximum or minimum flow levels need to be monitored automatically. Also can be used in conjunction with a control relay to power alternate equipment or monitoring devices.

## PRINCIPLE OF OPERATION

A small LED sensor and receiver are mounted on one side of the flow meter. The float inside the flow tube is detected as it passes across the beam of light. Sensor can be used to detect float passage beyond the setpoint of the sensor, or also can be set to monitor float position at specific level, signalling when float is outside of the range of the sensor light beam.

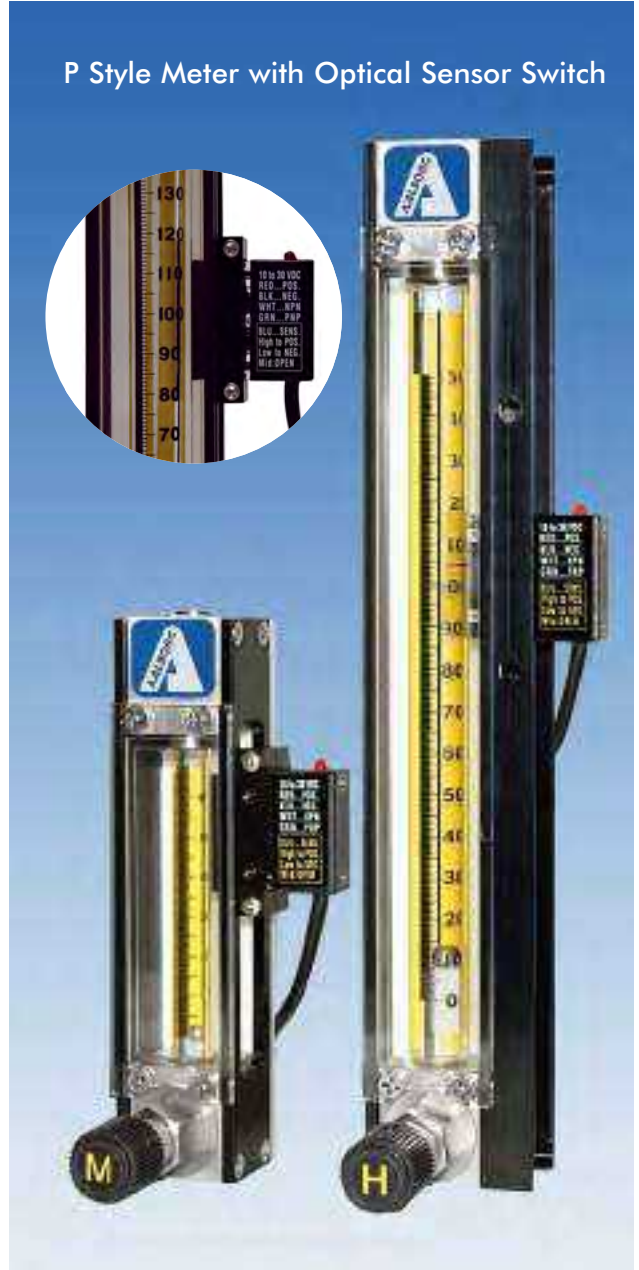

SPECIFICATIONS	
<b>MODE OF DETECTION</b>	Red LED beam break.
<b>POWER REQUIREMENTS</b>	10 to 30 Vdc @50 mA max.
<b>OUTPUT TRANSISTORS</b>	NPN (1) and PNP (1) output transistors provided.
<b>NPN</b>	Sink up to 100 mA.
<b>PNP</b>	Source up to 100 mA.
<b>RESPONSE TIME</b>	500 msec.
<b>LIGHT IMMUNITY</b>	Pulse modulated to provide extremely high immunity to ambient light.
<b>AMBIENT TEMPERATURE</b>	-30 + 70 degree C operating range.
<b>SENSOR CONSTRUCTION</b>	High impact polycarbonate housing. Epoxy encapsulated for mechanical strength.
<b>LIGHT SOURCE</b>	LED
<b>WAVELENGTH</b>	High intensity red = 650 nm connections.

Used in conjunction with P, S and T Style Flow Meters

To order a flow meter with a single Optical Sensor Switch add "E1-" to P, S, to T Model Numbers.  
Example: E1-P11A4-BA0A-032-41-ST-VN

OPTICAL SENSOR SWITCH CONNECTION	
WIRE LEAD COLOR	CONNECTION
BLACK	Positive Power Lead (+10 to 30 VDC)
WHITE	Negative Power Lead
GREEN*	PNP (Current Source) - to Positive of Load
WHITE*	NPN (Current Sink) - to Positive of Load
BLUE	Connect to Red Lead + Power

ORDERING INFORMATION FOR OPTICAL SENSOR SWITCH ACCESSORY	
PART NUMBER	DESCRIPTION
OSS-6-P	Optical Sensor Switch for 65mm P Style Meter
OSS-1-P	Optical Sensor Switch for 150mm P Style Meter
OSS-6-S	Optical Sensor Switch for 65mm S Style Meter
OSS-1-S	Optical Sensor Switch for 150mm S Style Meter
OSS-6-T	Optical Sensor Switch for 65mm T Style Meter
OSS-1-T	Optical Sensor Switch for 150mm T Style Meter

## GENERAL DESCRIPTION

The 150mm High /Low Alarm Flow Meter with the **Optical Sensor Switch** is a non-invasive means for detecting flows. This switch is ideal for signaling an alarm, as the float interrupts the sensor light beams (alarm, valve etc. not included).

**Helps protect your processes and equipment from damage caused by extreme flow rates.**

Its compact design and ease of operation make it a non-obtrusive simple-to-use addition to your flow meter.

Perfect for OEM applications. Also can be used in conjunction with a control relay to power alternate equipment or monitoring devices.

**Use whenever maximum or minimum flow levels need to be monitored automatically.**

### \*\*MATERIALS OF CONSTRUCTION

**END BLOCKS:** Aluminum or 316 Stainless Steel.

**ELASTOMERS:** Buna® & Viton® (Aluminum), Viton® (316 SS).

**TUBE:** Borosilicate.

### INTERFACE CONNECTION

RELAY #1	COM.	5
RELAY #1	N.O.	9
RELAY #1	N.C.	4
RELAY #2	COM.	8
RELAY #2	N.O.	3
RELAY #2	N.C.	7
External Reset		2
Common Power		6
Plus Power		1

DB9M Connector

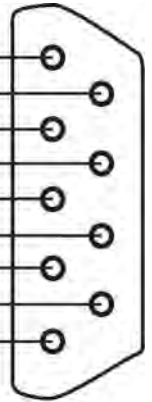

*\*\*The selection of materials of construction, is the responsibility of the customer. The company accepts no liability.*



### SPECIFICATIONS

<b>REPEATABILITY:</b>	0.5% of full scale.
<b>AMBIENT TEMPERATURE:</b>	0-70 deg. C
<b>MAXIMUM PRESSURE:</b>	200 PSIG
<b>CONNECTIONS:</b>	1/8" FNPT
<b>INPUT POWER:</b>	12 VDC, 15 VDC maximum, 250mA regulated, peak to peak maximum 100mA.
<b>POWER CONSUMPTION:</b>	Less than 100mA.
<b>RESPONSE TIME:</b>	500 milliseconds.
<b>SOURCE OF LIGHT:</b>	65 nm, red LED.
<b>LIGHT IMMUNITY:</b>	Pulse modulated.
<b>DRY CONTACT CLOSURES:</b>	2 normally open, and normally closed relay's.
<b>ALARM:</b>	70 dB audible buzzer and /or visual LED.
<b>ALARM OPTIONS:</b>	High, Low or High/Low.
<b>BUZZER:</b>	User configurable, momentary or latch.
<b>RESET:</b>	Reset button or remote through "D"-connector, to disable relay or buzzer.
<b>INTERFACE:</b>	9-pin "D"-connector.
<b>OPTIONAL:</b>	12VDC Power Supply, Tripod Base.



## PRINCIPLE OF OPERATION

LED Receiver / Sensors are mounted at each side of the flow meter. The position of the float inside the flow tube is detected as it passes across the sensor light beam. The sensor can alternately be used to detect float passage beyond a set point, or it can be set to monitor the float position at a specific level, signalling when the float is outside of the range of the sensor light beams.

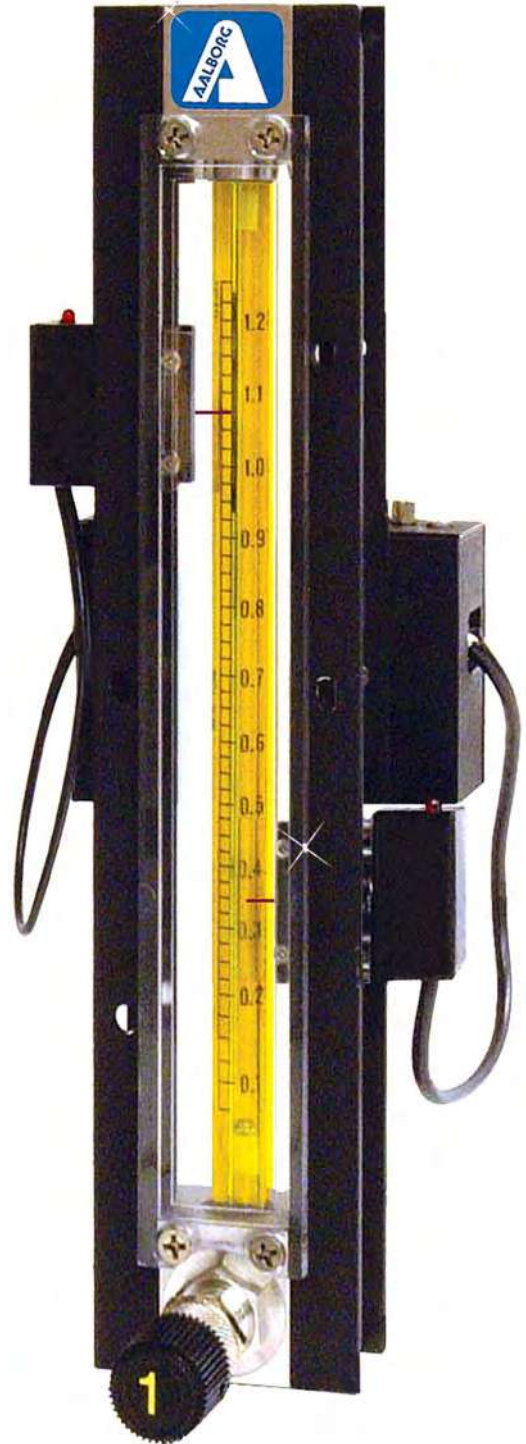

Stainless Steel Meter with High Precision Valve

ORDERING INFORMATION OPTICAL SENSOR SWITCH 150MM HIGH / LOW ALARM FLOW METERS					
MODEL NUMBER		MAX FLOW		FLOAT	
ALUMINUM	STAINLESS STEEL	[mL/min] Air	[mL/min] H <sub>2</sub> O		
<b>STANDARD VALVE</b>					
E2-P11A4-BA0A-032-41-GL-VN	E2-P11S4-VA0A-032-41-GL-VN	49	0.49	GL	
E2-P11A4-BA0A-062-01-GL-VN	E2-P11S4-VA0A-062-01-GL-VN	92	0.9	GL	
E2-P11A4-BA0A-062-01-ST-VN	E2-P11S4-VA0A-062-01-ST-VN	264	4.7	ST	
E2-P11A4-BA0A-112-02-GL-VN	E2-P11S4-VA0A-112-02-GL-VN	374	5.5	GL	
E2-P11A4-BA0A-112-02-ST-VN	E2-P11S4-VA0A-112-02-ST-VN	814	20.4	ST	
E2-P11A4-BA0A-082-03-ST-VN	E2-P11S4-VA0A-082-03-ST-VN	1682	44.6	ST	
E2-P11A4-BA0A-092-04-GL-VN	E2-P11S4-VA0A-092-04-GL-VN	2313	54	GL	
E2-P11A4-BA0A-092-04-ST-VN	E2-P11S4-VA0A-092-04-ST-VN	4662	133	ST	
E2-P11A4-BA0A-102-05-ST-VN	E2-P11S4-VA0A-102-05-ST-VN	7825	217	ST	
E2-P11A4-BA0A-034-39-ST-VN	E2-P11S4-VA0A-034-39-ST-VN	16,737	506	ST	
E2-P11A4-BA0A-044-40-GL-VN	E2-P11S4-VA0A-044-40-GL-VN	23,742	541	GL	
E2-P11A4-BA0A-044-40-ST-VN	E2-P11S4-VA0A-044-40-ST-VN	45,227	1288	ST	
E2-P11A4-BA0A-044-40-TA-VN	E2-P11S4-VA0A-044-40-TA-VN	69,940	2000	TANT	
<b>HIGH PRECISION VALVE</b>					
E2-P11A1-BA0A-032-41-GL-VN	E2-P11S1-VA0A-032-41-GL-VN	49	0.49	GL	
E2-P11A1-BA0A-062-01-GL-VN	E2-P11S1-VA0A-062-01-GL-VN	92	0.9	GL	
E2-P11A1-BA0A-062-01-ST-VN	E2-P11S1-VA0A-062-01-ST-VN	264	4.7	ST	
E2-P11A1-BA0A-112-02-GL-VN	E2-P11S1-VA0A-112-02-GL-VN	374	5.5	GL	
E2-P11A1-BA0A-112-02-ST-VN	E2-P11S1-VA0A-112-02-ST-VN	814	20.4	ST	
E2-P11A1-BA0A-082-03-ST-VN	E2-P11S1-VA0A-082-02-ST-VN	1682	44.6	ST	
E2-P11A1-BA0A-092-04-GL-VN	E2-P11S1-VA0A-092-04-GL-VN	2313	54	GL	
E2-P11A1-BA0A-092-04-ST-VN	E2-P11S1-VA0A-092-04-ST-VN	4662	133	ST	
E2-P11A1-BA0A-102-05-ST-VN	E2-P11S1-VA0A-102-05-ST-VN	7825	217	ST	
E2-P11A1-BA0A-034-39-ST-VN	E2-P11S1-VA0A-034-39-ST-VN	16,737	506	ST	
E2-P11A1-BA0A-044-40-GL-VN	E2-P11S1-VA0A-044-40-GL-VN	23,742	541	GL	
E2-P11A1-BA0A-044-40-ST-VN	E2-P11S1-VA0A-044-40-ST-VN	45,227	1288	ST	
E2-P11A1-BA0A-044-40-TA-VN	E2-P11S1-VA0A-044-40-TA-VN	69,940	2000	TANT	

OPTIONAL ACCESSORIES OPTICAL SENSOR SWITCH	
MODEL NUMBER	DESCRIPTION
PS-GFM-110NA-2	Power Supply 110vac/12Vdc (North America)
PS-GFM-230EU-2	Power Supply 230vac/12Vdc (Europe)
PS-GFM-240AU-2	Power Supply 240vac/12Vdc (Australia)
PS-GFM-240UK-2	Power Supply 240vac/12Vdc (United Kingdom)
TPI	Tripod for Single Tube Meter

To blend two or three gases in homogeneous infinitely variable concentrations, directly at the end use point, this *Model G* gas proportioner is unsurpassed in convenience and economy.

Gas proportioners pay for themselves since they eliminate the need for expensive custom blended gas mixtures.

They lend flexibility and economy to the utilization of component gas cylinders and "piped-in" supply lines.

**Another advantage in laboratory investigations is the freedom to reproducibility increase or decrease concentrations during the course of an experiment.**

The flow rates are not affected by downstream pressure variations as long as back pressures do not approach or exceed the input pressure. Input pressures of up to 200 psig (13.8 bars) can be used; however, customers very often find 50 psig (3.45 bars) a convenient setting to work with.

### design features

- ✓ Blending of two or three gases with gas proportioners obviates the need for:
  - ✓ ORDERING FIXED GAS MIXTURES.
  - ✓ CONTAMINATION FROM REUSABLE GAS CYLINDERS.
  - ✓ POTENTIALLY INACCURATE MIXTURES BY GAS SUPPLIERS.
- ✓ Rib-guided or fluted metering tubes facilitate stable, accurate readings.
- ✓ OPTIGRAD™ scales minimize parallax and eye fatigue.
- ✓ Interchangeability of flow tubes and floats.
- ✓ Simple means of panel mounting.



Gas Proportioner with CV™ valve for blending two gases



## BUILT-IN VALVES

Meters are available with built-in needle valves (CV™), high precision metering valves (MFV™) with “non-rising stems”, or with no valves.

The higher cost of MFV™ valves is justified whenever high sensitivity control and resolution are desirable particularly in conjunction with metering tubes of very low flow rates.

### flow tubes

- ✓ Precision fabricated from heavy walled, shock resistant borosilicate glass.
- ✓ Bores are uniformly tapered or formed with internal “rib-guides” or flutes.
- ✓ Floats are retained by TFE plugs.
- ✓ Self cleaning.
- ✓ Low differential pressures that stay independent of flow rate changes.

DIMENSIONS FOR G STYLE METERS		
WIDTH (W)		
SCALE LENGTH	2 CHANNEL	3 CHANNEL
150mm	3.24	4.24

Bench mounting acrylic tripod bases are optional.

## DIMENSIONS

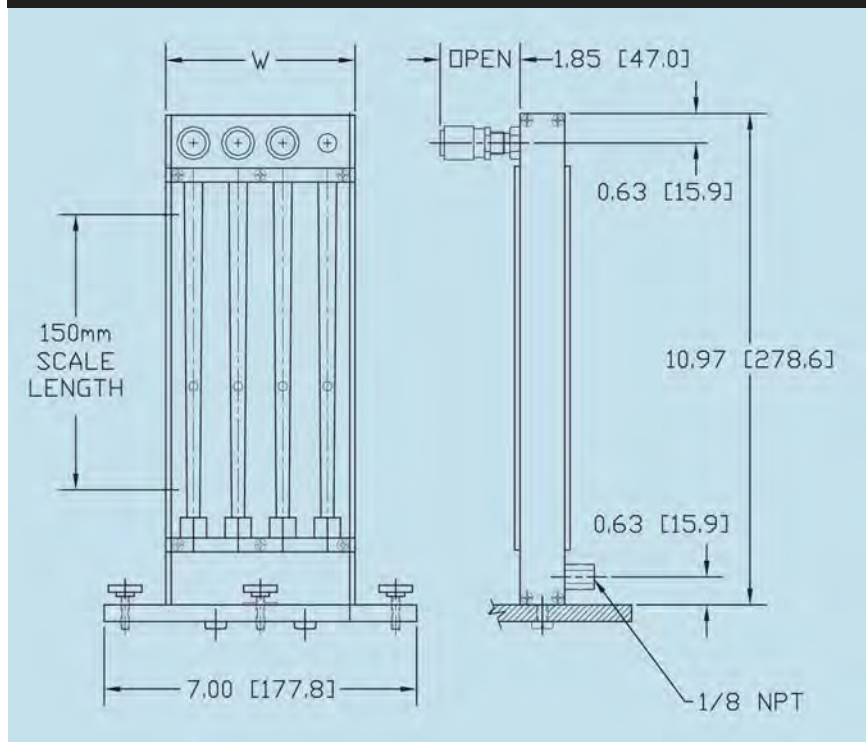

## SPECIFICATIONS STANDARD COMPONENT

### FLOW TUBE ACCURACY

±2% FS mm scales except 042 flow tubes ±5%, from 10 to 100% of scale. Conforming to ISA RP. 16-1.2.3. Specification 2-S-10.

### COMPONENT FLOW TUBE REPEATABILITY

±0.25%. Typical calibration curves for air at 50 psig /3.5 bars using glass floats are available. Consult the company on the availability of calibration data for non-hazardous gases and special individual calibrations.

**MAX OPERATING PRESSURE** 200 psig/13.8 bars.

**MAX OPERATING TEMPERATURE** 250 °F /121 °C.

## \*\*MATERIALS OF CONSTRUCTION

<b>FLOW TUBES</b>	Heavy walled borosilicate glass.
<b>CHOICE OF MOUNTING FITTINGS IN CONTACT WITH GASES</b>	a) Aluminum, black anodized. b) 316 stainless steel.
<b>SIDE PANELS</b>	Aluminum, black anodized.
<b>FRONT SHIELD</b>	Clear polycarbonate.
<b>BACK PLATE</b>	1/8" thick white acrylics.
<b>O-RINGS AND PACKING</b>	Buna-N® O-rings in aluminum model. Viton-A® O-rings in stainless steel meters.
<b>OPTIONAL</b>	Viton®, PTFE/Kalrez®.
<b>CONNECTIONS</b>	1/8" NPT female inlet and outlet connections.
<b>OPTIONAL</b>	Hose and compression fittings are available.

*\*\*The selection of materials of construction, is the responsibility of the customer. The company accepts no liability.*

**Ordering information see page 23.  
For flow capacities see table 10 page 46.**



Designed especially for the laboratory these kits offer a diverse economical way of acquiring flow measurement capabilities. Since all 150 mm flow tubes in this catalog are interchangeable, additional flow tubes may be added later (see flow tables, pages 43 to 49). A handy selection of flow meters is presented in kit form.

THREE TYPES OF KITS ARE OFFERED

- ✓ Aluminum Flow Meter Kit.
- ✓ Stainless Steel Flow Meter Kit.
- ✓ PTFE Flow Meter Kit.

Kits are shipped in convenient molded plastic carrying cases. Flow tubes and floats are interchangeable in frames supplied facilitating overlapping flow ranges.

**For non-corrosive fluids use the Aluminum Kit. For corrosives consider the Stainless Steel Kit. For corrosive applications at lower pressure or for high purity fluid service specify the PTFE Kit.**

All three units are supplied with glass floats installed.

Aluminum and Stainless Steel kits come with spare stainless steel and tantalum interchangeable floats to extend flow capacities. Due to chemical compatibility considerations PTFE kits are supplied with spare sapphire floats.

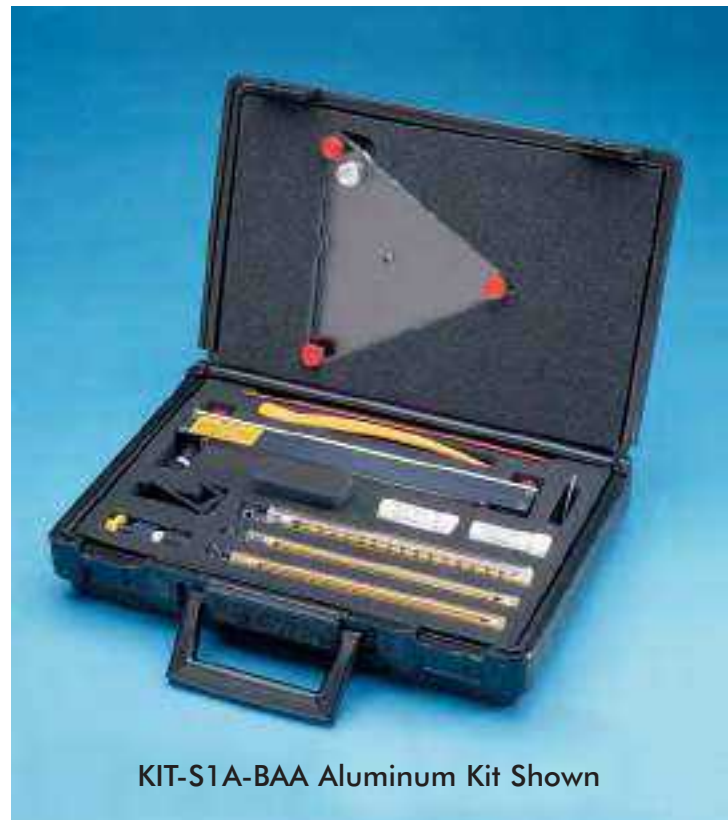

KIT-S1A-BAA Aluminum Kit Shown

FLOW CAPACITIES OF FLOW TUBES USED IN KITS [mL/min]						
FLOW TUBE NUMBER	FLOAT MATERIAL					
	GLASS		SAPPHIRE		STAINLESS STEEL	
	AIR	WATER	AIR	WATER	AIR	WATER
042-15	1.8 to 18.9	0.02 to 0.19	2.9 to 30	.04 to .38	5.8 to 60.6	0.09 to .945
112-02	21 to 374	.023 to 5.5	29 to 513	.39 to 9.96	36 to 814	1.1 to 20.4
102-05	135 to 3922	2 to 84	198 to 5188	3 to 126	351 to 7825	6 to 217
044-40	791 to 23742	15 to 541	1208 to 30711	30 to 806	2182 to 45227	57 to 1288

ORDERING INFORMATION FOR FLOW METER KITS		
MODEL NUMBER	CONTENTS	DESCRIPTION
KIT-S1A-BA	<b>ALUMINUM FLOW METER KIT:</b> Assembled with 042-15-GL flow tube. Extra flow tubes as listed in above table. Stainless steel float for 042,112 and 102 flow tubes. Tantalum float for 044 flow tube. High flow valve cartridge. Tripod base, tweezers, pushrod and locking tool for changing floats and flow tubes. Calibration data and carrying case.	Wetted parts are borosilicate glass, aluminum, 316 stainless steel. Buna-N® o-rings and Viton® packings.
KIT-S1S-VA	<b>STAINLESS STEEL FLOW METER KITS:</b> Assembled with 042-15-GL flow tube. Extra flow tubes as listed in above table. Stainless steel float for 042, 112 and 102 flow tubes. Tantalum float for 044 flow tube. High flow valve cartridge. Tripod base, tweezers, pushrod and locking tool for changing floats and flow tubes. Calibration data and carrying case.	Wetted parts are borosilicate glass, 316 stainless steel, Viton® o-rings and packings.
KIT-T1T-TA	<b>PTFE FLOW METER KIT:</b> Assembled with 042-15-GL flow tube. Extra flow tubes as listed in above table. Sapphire floats. High flow valve cartridge. Tripod base, tweezers, pushrod and locking tool for changing floats and flow tubes. Calibration data and carrying case.	Wetted parts are borosilicate glass, PTFE and PCTFE.

BULLETIN EM201007 K

# V

## MEDIUM RANGE BRASS AND STAINLESS FLOW METERS

Incorporating traditional rotameter precision glass technology, these rugged brass and stainless steel flow meters offer accurate and economical solutions to medium flow range measurements. **V meters** are designed with unique rotatable scales of dual air-water direct reading graduations showing SCFM and L/min (air), as well as GPM and LPM (water) markings.

### design features

- ✓ Rigid, compact construction.
- ✓ Dual, rotatable direct reading scales for air and water.
- ✓ Graduations reflect both metric and English systems.
- ✓ Vertical In-line or Panel Mount.
- ✓ Flow ranges from 4 to 20 L/min water and 140 to 900 L/min air.

### SPECIFICATIONS

<b>SCALES</b>	Rotatable, direct reading air, (SCFM-L/min) and water (GPM-LPM).
<b>ACCURACY</b>	±5% of full scale.
<b>MAXIMUM TEMPERATURE</b>	250 °F (121 °C).
<b>MAXIMUM PRESSURE</b>	150 psig (@200 °F).
<b>CONNECTIONS</b>	3/8" NPT female in line or horizontal rear.

### \*\*MATERIALS OF CONSTRUCTION

<b>TUBE SHIELDS</b>	Polycarbonate
<b>FLOW TUBES</b>	Heavy walled precision formed borosilicate glass.
<b>FLOATS</b>	Type 316 stainless steel.
<b>WETTED PARTS</b>	Brass or type 316 stainless steel.
<b>SEALS</b>	Viton® standard.
<b>OPTIONAL:</b>	Buna-N®, PTFE /Kalrez® and EPR.

\*\*The selection of materials of construction, is the responsibility of the customer. The company accepts no liability.

**Ordering information see page 27.**

### DIMENSIONS (IN LINE MODEL)

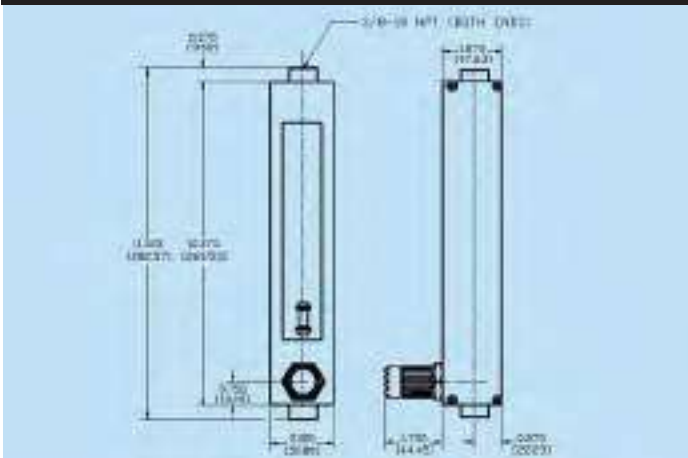

Panel Mount Meter with Valve



In-line Meter with Valve

### DIMENSIONS (PANEL MOUNT MODEL)

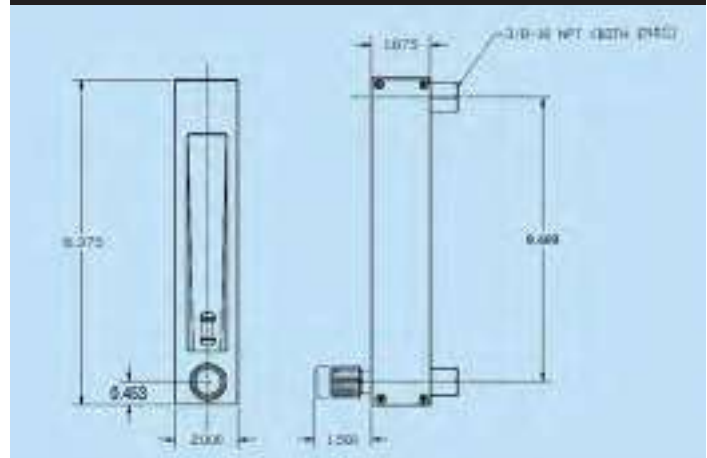



Incorporating traditional variable area precision glass technology, these rugged PTFE flow meters offer accurate and economical solutions to medium flow range measurements. **V meters** are designed with unique rotatable scales of dual air-water direct reading graduations showing SCFM and L/min (air), as well as GPM and LPM (water) markings.

### LEAK INTEGRITY

Flow meters are individually tested on a Mass Spectrometer Leak Detector and certified to a leak integrity rating of  $1 \times 10^{-7}$  sccs Helium or better.

### SPECIFICATIONS

<b>SCALES</b>	Rotatable, direct reading air, (SCFM-L/min) and water (GPM-LPM). Scale length is 127mm (nominal).
<b>ACCURACY</b>	±5% of full scale.
<b>MAXIMUM TEMPERATURE</b>	150 °F (65 °C.)
<b>MAXIMUM PRESSURE</b>	100 psig (6.7) bars.
<b>CONNECTIONS</b>	3/8" NPT female in line or horizontal rear.
<b>LEAK INTEGRITY</b>	Individually leak tested and certified.

### \*\*MATERIALS OF CONSTRUCTION

<b>TUBE SHIELDS</b>	Polycarbonate.
<b>FLOW TUBES</b>	Heavy walled precision formed borosilicate glass.
<b>FLOATS</b>	PTFE.
<b>WETTED PARTS</b>	PTFE, PCTFE.
<b>SEALS</b>	PTFE.

*\*\*The selection of materials of construction, is the responsibility of the customer. The company accepts no liability.*

**Ordering information see page 27.**

### DIMENSIONS (IN LINE MODEL)

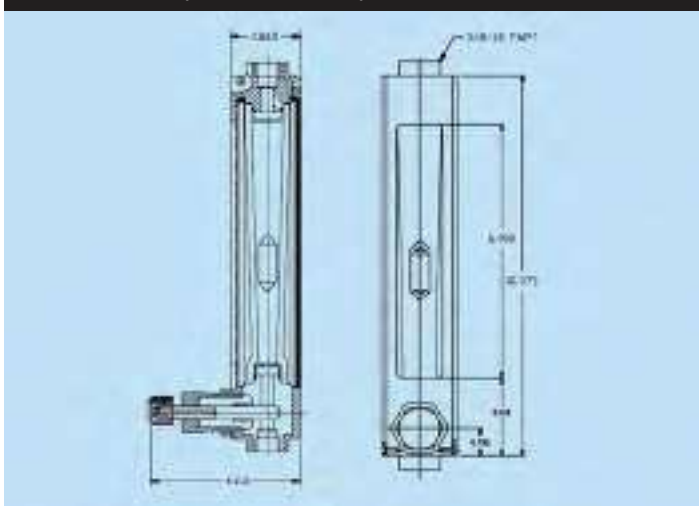

### DIMENSIONS (PANEL MOUNT MODEL)

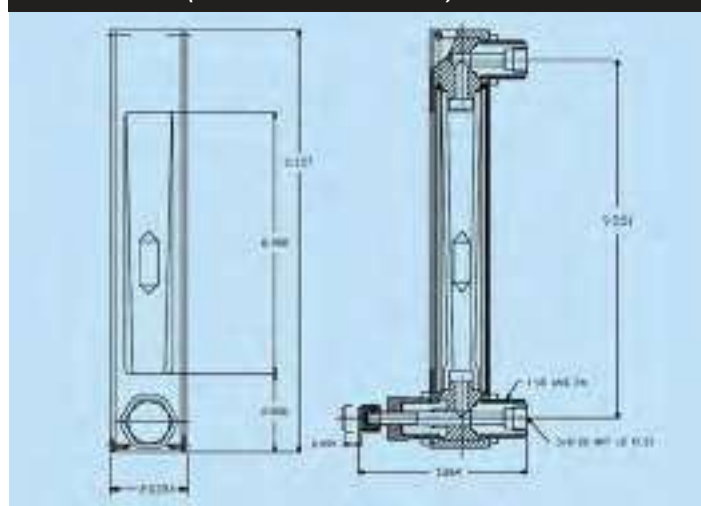



# ORDERING INFORMATION MEDIUM RANGE FLOW METERS

VERTICAL IN LINE							
MODEL NUMBER		END FITTING MATERIAL	MAXIMUM FLOW				
BUILT IN VALVE	NO VALVE		Air		Water		
			SCFM	L/min	GPM	LPM	
VIB4-VA-V01-01-ST	VIB3-VA-V01-01-ST	Brass	5	140	1.2	4	
VIB4-VA-V02-01-ST	VIB3-VA-V02-01-ST	Brass	10	280	2	8	
VIB4-VA-V03-01-ST	VIB3-VA-V03-01-ST	Brass	15	425	3	11.5	
VIB4-VA-V04-01-ST	VIB3-VA-V04-01-ST	Brass	20	575	4	15	
VIB4-VA-V05-01-ST	VIB3-VA-V05-01-ST	Brass	30	900	5	20	
VIS4-VA-V01-01-ST	VIS3-VA-V01-01-ST	316 s.s	5	140	1.2	4	
VIS4-VA-V02-01-ST	VIS3-VA-V02-01-ST	316 s.s	10	280	2	8	
VIS4-VA-V03-01-ST	VIS3-VA-V03-01-ST	316 s.s	15	425	3	11.5	
VIS4-VA-V04-01-ST	VIS3-VA-V04-01-ST	316 s.s	20	575	4	15	
VIS4-VA-V05-01-ST	VIS3-VA-V05-01-ST	316 s.s	30	900	5	20	

PANEL MOUNT METERS							
MODEL NUMBER		END FITTING MATERIAL	MAXIMUM FLOW				
BUILT IN VALVE	NO VALVE		Air		Water		
			SCFM	L/min	GPM	LPM	
VPB4-VA-V01-02-ST	VPB3-VA-V01-02-ST	Brass	5	140	1.2	4	
VPB4-VA-V02-02-ST	VPB3-VA-V02-02-ST	Brass	10	280	2	8	
VPB4-VA-V03-02-ST	VPB3-VA-V03-02-ST	Brass	15	425	3	11.5	
VPB4-VA-V04-02-ST	VPB3-VA-V04-02-ST	Brass	20	575	4	15	
VPB4-VA-V05-02-ST	VPB3-VA-V05-02-ST	Brass	30	900	5	20	
VPS4-VA-V01-02-ST	VPS3-VA-V01-02-ST	316 s.s	5	140	1.2	4	
VPS4-VA-V02-02-ST	VPS3-VA-V02-02-ST	316 s.s	10	280	2	8	
VPS4-VA-V03-02-ST	VPS3-VA-V03-02-ST	316 s.s	15	425	3	11.5	
VPS4-VA-V04-02-ST	VPS3-VA-V04-02-ST	316 s.s	20	575	4	15	
VPS4-VA-V05-02-ST	VPS3-VA-V05-02-ST	316 s.s	30	900	5	20	

PTFE VERTICAL IN LINE METERS							
MODEL NUMBER		END FITTING MATERIAL	MAXIMUM FLOW				
BUILT IN VALVE	NO VALVE		Air		Water		
			SCFM	L/min	GPM	LPM	
VIT4-TA-V06-01-TF	VIT3-TA-V06-01-TF	PTFE	3.5	100	0.8	3	
VIT4-TA-V07-01-TF	VIT3-TA-V07-01-TF	PTFE	7	200	1.5	5.75	
VIT4-TA-V08-01-TF	VIT3-TA-V08-01-TF	PTFE	10.5	300	2.2	8.25	
VIT4-TA-V09-01-TF	VIT3-TA-V09-01-TF	PTFE	14	400	2.9	11	
VIT4-TA-V10-01-TF	VIT3-TA-V10-01-TF	PTFE	17.5	500	3.5	13.25	
VIT4-TA-V11-01-TF	VIT3-TA-V11-01-TF	PTFE	22	625	4.1	16	

PTFE PANEL MOUNT METERS							
MODEL NUMBER		END FITTING MATERIAL	MAXIMUM FLOW				
BUILT IN VALVE	NO VALVE		Air		Water		
			SCFM	L/min	GPM	LPM	
VPT4-TA-V06-02-TF	VPT3-TA-V06-02-TF	PTFE	3.5	100	0.8	3	
VPT4-TA-V07-02-TF	VPT3-TA-V07-02-TF	PTFE	7	200	1.5	5.75	
VPT4-TA-V08-02-TF	VPT3-TA-V08-02-TF	PTFE	10.5	300	2.2	8.25	
VPT4-TA-V09-02-TF	VPT3-TA-V09-02-TF	PTFE	14	400	2.9	11	
VPT4-TA-V10-02-TF	VPT3-TA-V10-02-TF	PTFE	17.5	500	3.5	13.25	
VPT4-TA-V11-02-TF	VPT3-TA-V11-02-TF	PTFE	22	625	4.1	16	



Incorporating traditional rotameter precision glass technology, these rugged brass and stainless steel flow meters offer accurate and economical solutions to medium flow range measurements.

**xV meters** are designed with unique rotatable scales in either SCFM or L/min. Each features direct reading scales for 5 gases. (Argon, CO<sub>2</sub>, He, N<sub>2</sub>, & O<sub>2</sub>).

## design features

- ✓ Rigid, compact construction.
- ✓ Multi-gas, rotatable direct reading scales for 5 gases.
- ✓ Graduations reflect both metric or English systems.
- ✓ Vertical In-line or Panel Mount.

### SPECIFICATIONS

<b>SCALES</b>	Rotatable, direct reading Argon, CO <sub>2</sub> , He, N <sub>2</sub> , & O <sub>2</sub> .
<b>ACCURACY</b>	±5% of full scale.
<b>MAXIMUM TEMPERATURE</b>	250 °F (121 °C).
<b>MAXIMUM PRESSURE</b>	150 psig (@200 °F).
<b>CONNECTIONS</b>	3/8" NPT female in line or horizontal rear.

### \*\*MATERIALS OF CONSTRUCTION

<b>TUBE SHIELDS</b>	Polycarbonate.
<b>FLOW TUBES</b>	Heavy walled precision formed borosilicate glass.
<b>FLOATS</b>	Type 316 stainless steel.
<b>WETTED PARTS</b>	Brass or type 316 stainless steel.
<b>SEALS</b>	Viton® standard.
<b>OPTIONAL:</b>	Buna-N®, PTFE /Kalrez® and EPR.

*\*\*The selection of materials of construction, is the responsibility of the customer. The company accepts no liability.*



Typical meter shown with rotatable "scale drum"

### DIMENSIONS (IN LINE MODEL)

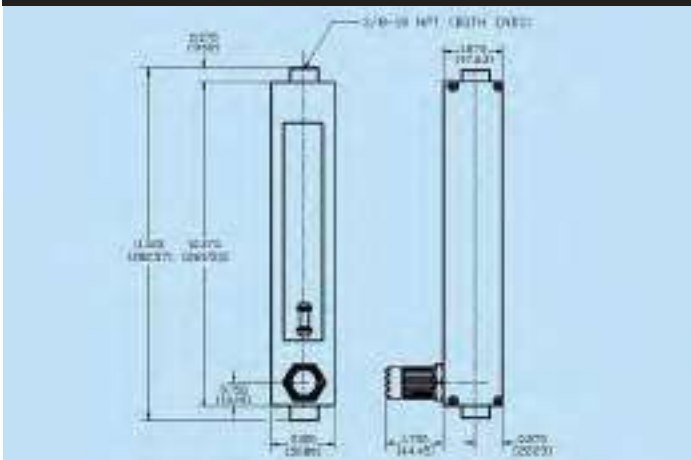

### DIMENSIONS (PANEL MOUNT MODEL)

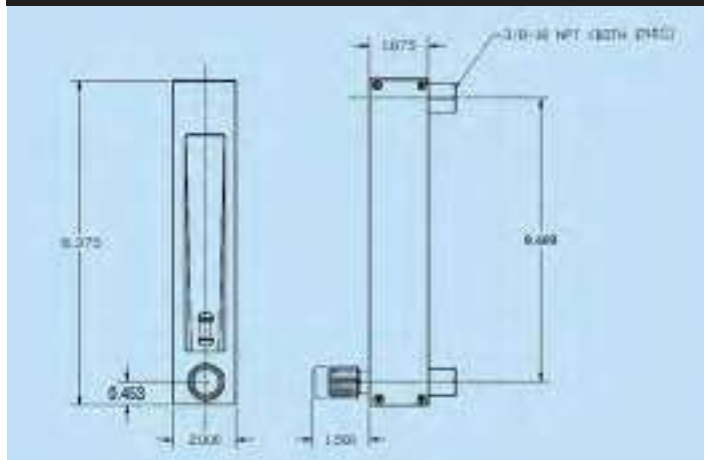



# DIRECT READING MULTI-GAS FLOW METERS

VERTICAL IN LINE							
MODEL NUMBER		END FITTING MATERIAL	MAXIMUM FLOW				
BUILT IN VALVE	NO VALVE		SCFM				
VIB4-VA-V01-03-ST	VIB3-VA-V01-03-ST	Brass	4.2	3.8	12.0	4.5	4.5
VIB4-VA-V02-03-ST	VIB3-VA-V02-03-ST	Brass	8.0	8.0	23.0	9.5	9.0
VIB4-VA-V03-03-ST	VIB3-VA-V03-03-ST	Brass	12.5	12.5	35.0	14.0	14.0
VIB4-VA-V04-03-ST	VIB3-VA-V04-03-ST	Brass	15.5	15.5	42.5	19.0	18.0
VIB4-VA-V05-03-ST	VIB3-VA-V05-03-ST	Brass	26.0	24.0	60.0	30.0	28.0
VIS4-VA-V01-03-ST	VIS3-VA-V01-03-ST	316 s.s.	4.2	3.8	12.0	4.5	4.5
VIS4-VA-V02-03-ST	VIS3-VA-V02-03-ST	316 s.s.	8.0	8.0	23.0	9.5	9.0
VIS4-VA-V03-03-ST	VIS3-VA-V03-03-ST	316 s.s.	12.5	12.5	35.0	14.0	14.0
VIS4-VA-V04-03-ST	VIS3-VA-V04-03-ST	316 s.s.	15.5	15.5	42.5	19.0	18.0
VIS4-VA-V05-03-ST	VIS3-VA-V05-03-ST	316 s.s.	26.0	24.0	60.0	30.0	28.0

VERTICAL IN LINE							
MODEL NUMBER		END FITTING MATERIAL	MAXIMUM FLOW				
BUILT IN VALVE	NO VALVE		L/min				
VIB4-VA-V01-05-ST	VIB3-VA-V01-05-ST	Brass	120	105	350	130	130
VIB4-VA-V02-05-ST	VIB3-VA-V02-05-ST	Brass	230	220	650	270	260
VIB4-VA-V03-05-ST	VIB3-VA-V03-05-ST	Brass	360	360	1000	400	400
VIB4-VA-V04-05-ST	VIB3-VA-V04-05-ST	Brass	440	440	1250	550	525
VIB4-VA-V05-05-ST	VIB3-VA-V05-05-ST	Brass	750	700	1800	850	800
VIS4-VA-V01-05-ST	VIS3-VA-V01-05-ST	316 s.s.	120	105	350	130	130
VIS4-VA-V02-05-ST	VIS3-VA-V02-05-ST	316 s.s.	230	220	650	270	260
VIS4-VA-V03-05-ST	VIS3-VA-V03-05-ST	316 s.s.	360	360	1000	400	400
VIS4-VA-V04-05-ST	VIS3-VA-V04-05-ST	316 s.s.	440	440	1250	550	525
VIS4-VA-V05-05-ST	VIS3-VA-V05-05-ST	316 s.s.	750	700	1800	850	800

PANEL MOUNT METERS							
MODEL NUMBER		END FITTING MATERIAL	MAXIMUM FLOW				
BUILT IN VALVE	NO VALVE		SCFM				
VPB4-VA-V01-04-ST	VPB3-VA-V01-04-ST	Brass	4.2	3.8	12.0	4.5	4.5
VPB4-VA-V02-04-ST	VPB3-VA-V02-04-ST	Brass	8.0	8.0	23.0	9.5	9.0
VPB4-VA-V03-04-ST	VPB3-VA-V03-04-ST	Brass	12.5	12.5	35.0	14.0	14.0
VPB4-VA-V04-04-ST	VPB3-VA-V04-04-ST	Brass	15.5	15.5	42.5	19.0	18.0
VPB4-VA-V05-04-ST	VPB3-VA-V05-04-ST	Brass	26.0	24.0	60.0	30.0	28.0
VPS4-VA-V01-04-ST	VPS3-VA-V01-04-ST	316 s.s.	4.2	3.8	12.0	4.5	4.5
VPS4-VA-V02-04-ST	VPS3-VA-V02-04-ST	316 s.s.	8.0	8.0	23.0	9.5	9.0
VPS4-VA-V03-04-ST	VPS3-VA-V03-04-ST	316 s.s.	12.5	12.5	35.0	14.0	14.0
VPS4-VA-V04-04-ST	VPS3-VA-V04-04-ST	316 s.s.	15.5	15.5	42.5	19.0	18.0
VPS4-VA-V05-04-ST	VPS3-VA-V05-04-ST	316 s.s.	26.0	24.0	60.0	30.0	28.0

PANEL MOUNT METERS							
MODEL NUMBER		END FITTING MATERIAL	MAXIMUM FLOW				
BUILT IN VALVE	NO VALVE		L/min				
VPB4-VA-V01-06-ST	VPB3-VA-V01-06-ST	Brass	120	105	350	130	130
VPB4-VA-V02-06-ST	VPB3-VA-V02-06-ST	Brass	230	220	650	270	260
VPB4-VA-V03-06-ST	VPB3-VA-V03-06-ST	Brass	360	360	1000	400	400
VPB4-VA-V04-06-ST	VPB3-VA-V04-06-ST	Brass	440	440	1250	550	525
VPB4-VA-V05-06-ST	VPB3-VA-V05-06-ST	Brass	750	700	1800	850	800
VPS4-VA-V01-06-ST	VPS3-VA-V01-06-ST	316 s.s.	120	105	350	130	130
VPS4-VA-V02-06-ST	VPS3-VA-V02-06-ST	316 s.s.	230	220	650	270	260
VPS4-VA-V03-06-ST	VPS3-VA-V03-06-ST	316 s.s.	360	360	1000	400	400
VPS4-VA-V04-06-ST	VPS3-VA-V04-06-ST	316 s.s.	440	440	1250	550	525
VPS4-VA-V05-06-ST	VPS3-VA-V05-06-ST	316 s.s.	750	700	1800	850	800

## design features

- ✓ Heavy duty stainless steel.
- ✓ Thick polycarbonate safety shields.
- ✓ Fluted or plain tapered tubes.
- ✓ Direct reading metric and English system scales.
- ✓ Unique design facilitates ease of maintenance cleaning processes.

Heavy-duty flow meters are fully enclosed in a brushed stainless steel case. Ideal for industrial applications with flow rates of up to 116 GPM / 440 L/min and 250 SCFM / 7080 L/min. Used for flow measurements of liquids (water) and gases (air).



Meters are graduated for direct reading of water and air. Flow meters come with FNPT or flanged end fittings for easy in-line installation. Wetted parts include borosilicate glass flow tubes, Viton® o-rings, and 316 Stainless steel fittings, guide rods, floats and float stops.

Flanged  
M Style Meter



In Line  
M Style Meters

### SPECIFICATIONS

<b>ACCURACY</b>	±3% of full scale.
<b>MINIMUM FLOW RATE</b>	Approximately 10% of maximum flow rate.
<b>REPEATABILITY</b>	±0.5% of full scale.
<b>MAXIMUM PRESSURE AT 200°F (93°C)</b>	200 psig / 13.6 bar gauge (tube size 3, 4, 5 and 6). 125 psig / 8.5 bar gauge (tube size 8 and 9).
<b>MAXIMUM OPERATING TEMPERATURE</b>	200 °F (93 °C).

### \*\*MATERIALS OF CONSTRUCTION

<b>FLOW TUBES</b>	Heavy walled borosilicate glass.
<b>FITTINGS IN CONTACT WITH FLUIDS</b>	316 Stainless Steel.
<b>FRONT SHIELD</b>	Thick clear polycarbonate and white acrylics.
<b>O-RINGS</b>	Viton®.
<b>OPTIONAL</b>	PTFE/ Kalrez®, EPR.
<b>CONNECTIONS</b>	IN LINE: 1/2", 1-1/2", 2", NPT. 150 ANSI FLANGED: 3/4", 1-1/2", 2-1/2".

\*\*The selection of materials of construction, is the responsibility of the customer. The company accepts no liability.

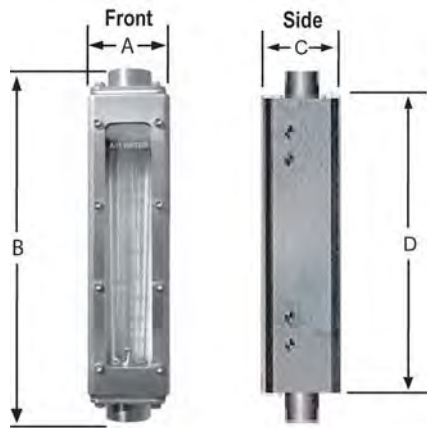

**DIMENSIONS FOR IN-LINE M STYLE METERS**

NPT (F)	A	B	C	D
1/2"	2	9.54	2.25	8.04
1"	3.5	13.69	3.75	10.50
2"	5	15.59	5.25	11.55

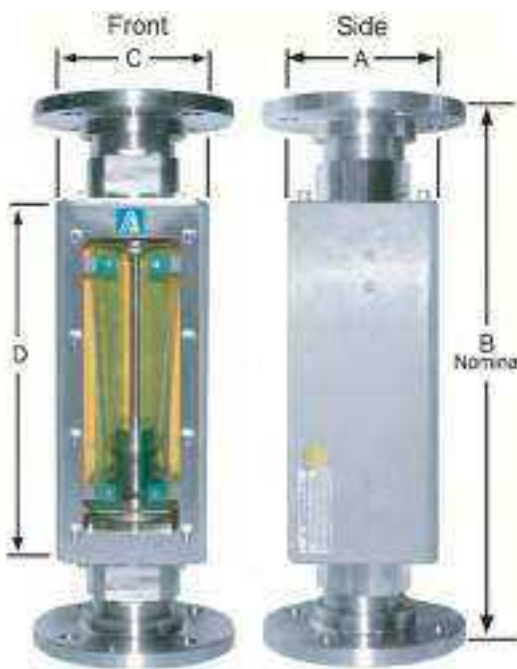

**DIMENSIONS FOR FLANGED M STYLE METERS**

Flange Size	A	B (Nominal)	C	D
3/4"	2	9.58	2.25	8.04
1 1/2"	3.5	14.15	3.75	10.50
2 1/2"	5	17.98	5.25	11.55

**IN LINE M STYLE METERS**

CATALOG NUMBER	MAX FLOW RATE				PRESSURE DROP ("OF H <sub>2</sub> O)	TUBE SIZE	NPT CONNECTION
	WATER [GPM]	AIR [SCFM]	WATER [L/min]	AIR [L/min]			
MS-VJ-M01-02-ST	0.25	1.2	.95	35	-	3	1/2"
MS-VJ-M02-02-ST	0.36	1.7	1.3	50	2	3	
MS-VJ-M03-02-ST	0.76	3.3	3.0	90	5	3	
MS-VJ-M04-02-ST	1.0	4.2	3.7	120	6	4	
MS-VJ-M05-02-ST	1.5	6.5	5.6	180	-	4	
MS-VJ-M06-02-ST	2.2	8.5	8.2	250	10	4	
MS-VK-M07-02-ST	3.8	16	14	475	10	5	1"
MS-VK-M08-02-ST	5.0	21.5	18	650	14	5	
MS-VK-M09-02-ST	6.0	25.5	20	725	5	6	
MS-VK-M10-02-ST	7.4	30	27.5	900	6	6	
MS-VK-M11-02-ST	9.6	40	35	1200	10	6	
MS-VK-M12-02-ST	11	47.5	40	1400	13	6	
MS-VK-M13-02-ST	14	62	50	1800	24	6	2"
MS-VK-M14-02-ST	20	90	75	2600	39	6	
MS-VL-M15-02-ST	22	90	83	2550	16	8	1"
MS-VK-M16-02-ST	26	-	98	-	70	6	
MS-VQ-M17-02-ST	41	160	155	4531	5	9	2"
MS-VL-M18-02-ST	44	180	167	5098	30	8	
MS-VQ-M19-02-ST	60	245	227	6938	16	9	
MS-VL-M20-02-ST	61	250	231	7080	40	8	
MS-VQ-M21-02-ST	86	-	326	-	25	9	
MS-VQ-M22-02-ST	116	-	439	-	45	9	

**FLANGED M STYLE METERS**

CATALOG NUMBER	MAX FLOW RATE				PRESSURE DROP ("OF H <sub>2</sub> O)	TUBE SIZE	FLANGE CONNECTION
	WATER [GPM]	AIR [SCFM]	WATER [L/min]	AIR [L/min]			
MS-VR-M01-02-ST	0.25	1.2	.95	35	-	3	3/4"
MS-VR-M02-02-ST	0.36	1.7	1.3	50	2	3	
MS-VR-M03-02-ST	0.76	3.3	3.0	90	5	3	
MS-VR-M04-02-ST	1.0	4.2	3.7	120	6	4	
MS-VR-M05-02-ST	1.5	6.5	5.6	180	-	4	
MS-VR-M06-02-ST	2.2	8.5	8.2	250	10	4	
MS-VS-M07-02-ST	3.8	16	14	475	10	5	1 1/2"
MS-VS-M08-02-ST	5.0	21.5	18	650	14	5	
MS-VS-M09-02-ST	6.0	25.5	20	725	5	6	
MS-VS-M10-02-ST	7.4	30	27.5	900	6	6	
MS-VS-M11-02-ST	9.6	40	35	1200	10	6	
MS-VS-M12-02-ST	11	47.5	40	1400	13	6	
MS-VS-M13-02-ST	14	62	50	1800	24	6	2 1/2"
MS-VS-M14-02-ST	20	90	75	2600	39	6	
MS-VT-M15-02-ST	22	90	83	2550	16	8	1 1/2"
MS-VS-M16-02-ST	26	-	98	-	70	6	
MS-VU-M17-02-ST	41	160	155	4531	5	9	2 1/2"
MS-VT-M18-02-ST	44	180	167	5098	30	8	
MS-VU-M19-02-ST	60	245	227	6938	16	9	
MS-VT-M20-02-ST	61	250	231	7080	40	8	
MS-VU-M21-02-ST	86	-	326	-	25	9	
MS-VU-M22-02-ST	116	-	439	-	45	9	

Made entirely of PTFE, PFA, and PCTFE, the *Model F* flow meter is excellent for high-purity applications or use with corrosive liquids.

Units are available with a standard valve to monitor and control flow or without a valve to just monitor flow.

Flow meters are individually tested on a Mass Spectrometer Leak Detector and certified to a leak integrity rating of  $1 \times 10^{-7}$  sccs Helium or better.

**design features**

- ✓ Chemically inert wetted components.
- ✓ Removable protective shield.
- ✓ Individually leak tested.



SPECIFICATIONS	
SCALES	0 to 10 markings.
ACCURACY	±5% of full scale.
MAXIMUM TEMPERATURE	250 °F (121 °C).
MAXIMUM PRESSURE	100 psig (6.7 bars).
LEAK INTEGRITY	Individually, leak tested and certified to a rating of $1 \times 10^{-7}$ sccs of Helium.

**MATERIALS OF CONSTRUCTION	
TUBE SHIELDS	Polycarbonate.
FLOW TUBES	PFA.
FLOATS	PTFE.
WETTED PARTS	PTFE end fittings. PCTFE guide rods.

*\*\*The selection of materials of construction, is the responsibility of the customer. The company accepts no liability.*

DIMENSIONS FOR F STYLE METERS	
LOW RANGE MODELS	HIGH RANGE MODELS
5-11/16" Length x 1-1/4" O.D.	10-1/2" Length x 2" O.D.

**ORDERING INFORMATION**

F STYLE LOW RANGE METERS				
MODEL NUMBER		CONNECTION	MAXIMUM FLOW	
BUILT IN VALVE	NO VALVE		[mL/min] WATER	[gph] WATER
F6C-F01-01-TF	F3C-F01-01-TF	1/4" FNPT	125	1.98
F6C-F02-01-TF	F3C-F02-01-TF	1/4" FNPT	250	3.96
F6C-F03-01-TF	F3C-F03-01-TF	1/4" FNPT	400	6.34
F6C-F04-01-TF	F3C-F04-01-TF	1/4" FNPT	500	7.92
F6C-F05-01-TF	F3C-F05-01-TF	1/4" FNPT	1000	15.85
F6D-F06-01-TF	F3D-F06-01-TF	3/8" FNPT	2000	31.69
F6D-F07-01-TF	F3D-F07-01-TF	3/8" FNPT	2500	39.62
F6D-F08-01-TF	F3D-F08-01-TF	3/8" FNPT	3000	47.54
F6D-F09-01-TF	F3D-F09-01-TF	3/8" FNPT	5000	79.23

F STYLE HIGH RANGE METERS				
MODEL NUMBER		CONNECTION	MAXIMUM FLOW	
BUILT IN VALVE	NO VALVE		[L/min] WATER	[gpm] WATER
F8E-F10-01-TF	F3E-F10-01-TF	1/2" FNPT	13	3.43
F8E-F11-01-TF	F3E-F11-01-TF	1/2" FNPT	20	5.28
F8F-F12-01-TF	F3F-F12-01-TF	3/4" FNPT	30	7.93
F8F-F13-01-TF	F3F-F13-01-TF	3/4" FNPT	40	10.57
F6F-F14-01-TF	F3F-F14-01-TF	3/4" FNPT	45	11.89

# L

## PTFE-PFA FLOW METERS

Incorporating the principles of traditional rotameter flow technology, these rugged PTFE-PFA flow meters offer solutions to low to medium flow range measurements of highly corrosive or ultra-pure liquids.

Wetted inert components are surrounded by structurally rigid materials such as PFA-clad aluminum, KYNAR®. The resultant design represents a unique combination of a rugged mechanically rigid frame and the chemically inert wetted parts. *Model L* Meters are constructed of inert materials such as PFA, PTFE and PCTFE.

**Flow meters are also resistant to external, ambient corrosives.**

For the protection of personnel each flow meter is supplied with a safety shield.

Flow meters are supplied with or without built-in needle valves and they are panel mountable, by means of KYNAR® panel nuts.

### design features

- ✓ Chemically inert wetted components constructed from PFA PTFE and PCTE.
- ✓ Non-fluid contacting structurally rigid frame constructed from PFA-clad aluminum and KYNAR®.
- ✓ Overlapping flow ranges are available for water from 5 mL/min (0.00132 GPM) to 45 L/min (12 GPM).
- ✓ Individually leak tested.

### LEAK INTEGRITY

Flow meters are individually tested on a Mass Spectrometer Leak Detector and certified to a leak integrity rating of  $1 \times 10^{-7}$  sccs Helium or better.

High Range PTFE meter with Valve

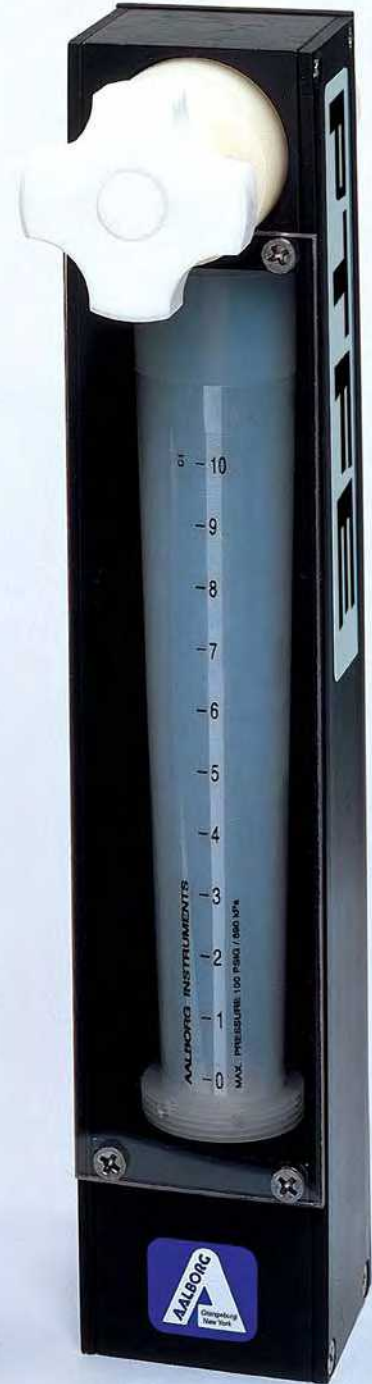

Low Range PTFE meter without Valve



## PRINCIPLES OF OPERATION

A cylindrical float freely moving inside a tapered flow tube comprises the flow measurement element of PTFE - PFA flow meters. The translucent PFA flow tube is installed vertically in-line in the liquid stream.

As flow takes place the float is propelled up inside the flow tube. The area between the float and the inside diameter of the flow tube gradually increases with increasing flow and correspondingly the pressure lifting the float decreases until the weight of the float and its buoyant force come to equilibrium.

**At equilibrium the top of the float is lined up with a scale graduation on the flow tube denoting a discrete rate of flow.**

## MOUNTING DIMENSIONS

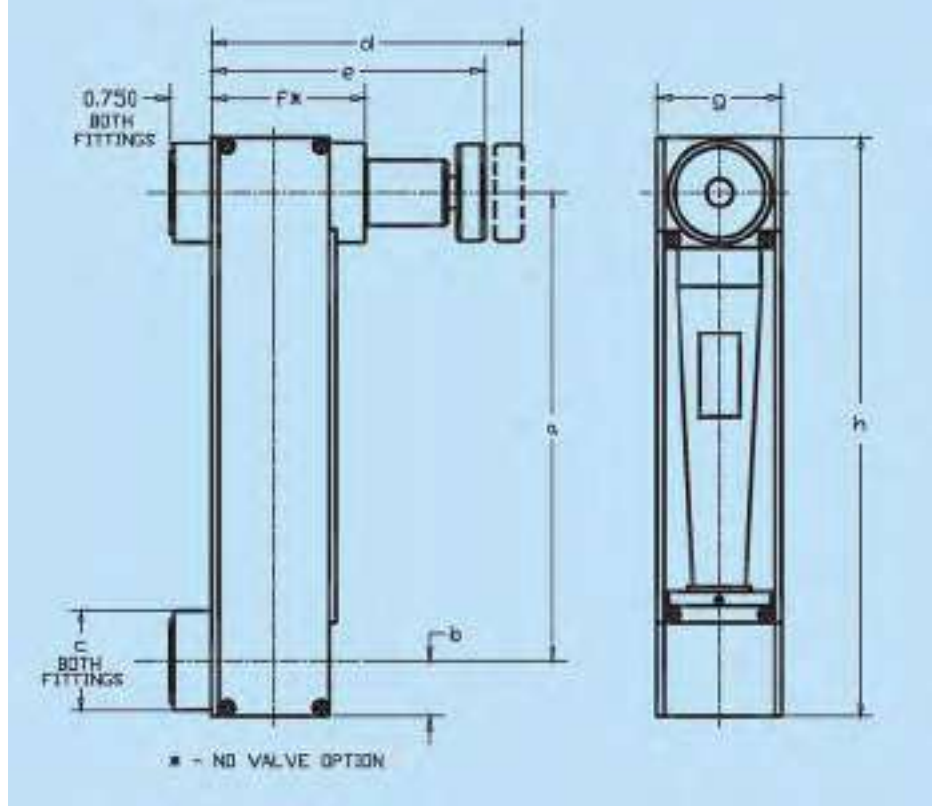

SPECIFICATIONS	
SCALES	0 to 10 markings (see dimension table for scale lengths).
ACCURACY	±5% of full scale.
MAXIMUM TEMPERATURE	250° F (121°C).
MAXIMUM PRESSURE	100 psig (6.7 bars).
LEAK INTEGRITY	Individually pressure and leak tested and certified to a rating of 1 x 10 <sup>-7</sup> sccs of Helium.

**MATERIALS OF CONSTRUCTION	
FLOW TUBES	PFA.
FLOATS	PTFE.
WETTED PARTS	PFA (flow tubes) and PTFE (end fittings and floats) and PCTFE (guide rods).

\*\*The selection of materials of construction, is the responsibility of the customer. The company accepts no liability.

DIMENSIONS FOR L STYLE METERS									
METER SIZE	A	B	C	D	E	F	G	H	SCALE LENGTH
C	4.97	0.56	1.06	3.35	3.15	1.52	1.25	6.16	75mm.
D	4.97	0.56	1.25	4.65	4.25	1.82	1.50	6.16	75mm.
E	8.72	0.88	1.75	4.57	4.07	2.12	2.00	10.4	125mm
F	8.47	1.00	1.75	5.95	5.00	2.32	2.25	10.4	125mm

\* Dimensions are in inches, except as shown in [mm]; for certified dimensions contact the company.

ORDERING INFORMATION				
L STYLE LOW RANGE METERS				
MODEL NUMBER		CONNECTION	MAXIMUM FLOW	
BUILT IN VALVE	NO VALVE		[mL/min] WATER	[gph] WATER
L6C-L01-01-SA	L3C-L01-01-SA	1/4" FNPT	75	1.19
L6C-L02-01-TF	L3C-L02-01-TF	1/4" FNPT	250	3.96
L6C-L03-01-TF	L3C-L03-01-TF	1/4" FNPT	400	6.34
L6C-L04-01-TF	L3C-L04-01-TF	1/4" FNPT	500	7.92
L6C-L05-01-TF	L3C-L05-01-TF	1/4" FNPT	1000	15.85
L6D-L06-01-TF	L3D-L06-01-TF	3/8" FNPT	2000	31.69
L6D-L07-01-TF	L3D-L07-01-TF	3/8" FNPT	2500	39.62
L6D-L08-01-TF	L3D-L08-01-TF	3/8" FNPT	3000	47.54
L6D-L09-01-TF	L3D-L09-01-TF	3/8" FNPT	5000	79.23

L STYLE HIGH RANGE METERS				
MODEL NUMBER		CONNECTION	MAXIMUM FLOW	
BUILT IN VALVE	NO VALVE		[L/min] WATER	[gpm] WATER
L6E-L10-01-TF	L3E-L10-01-TF	1/2" FNPT	13	3.43
L6E-L11-01-TF	L3E-L11-01-TF	1/2" FNPT	20	5.28
L6F-L12-01-TF	L3F-L12-01-TF	3/4" FNPT	30	7.93
L6F-L13-01-TF	L3F-L13-01-TF	3/4" FNPT	40	10.57
L6F-L14-01-TF	L3F-L14-01-TF	3/4" FNPT	45	11.89

## BARSTOCK METERING VALVES MFV™

Offered in straight (T) and 90 degree (L) flow patterns, the MFV™ Barstock Valve includes a “non-rising stem” design, it’s unique non-rotating needle is cylindrical with a precision ground tapered metering surface. The needle moves in a rectilinear fashion which accounts for its desirable sixteen- turn high resolution attribute. Hysteresis is virtually eliminated due to the needle design and the closely fitting fine thread on its adjustment plunger. The valve body is precision machined chrome plated brass or type 316 stainless steel.



Designed for controlling very low flow rates of liquids and gases, MFV™ Barstock valves are available in six conveniently overlapping orifice-needle sizes.

### design features

- ✓ Virtually free of hysteresis (see-sawing).
- ✓ Bubble tight shutoff.
- ✓ Straight or 90 degree flow patterns.
- ✓ Brass or 316 stainless steel high resolution.
- ✓ Sixteen turns to full open.

### SPECIFICATIONS

<b>MAXIMUM PRESSURE</b>	500 psig (3792 kPa).
<b>MAXIMUM TEMPERATURE</b>	180 °F (82 °C)-brass. 250 °F (121 °C)-stainless.
<b>VALVE STEM</b>	Sixteen turns, non-rising type.

### \*\*MATERIALS OF CONSTRUCTION

<b>BODY</b>	Chrome plated brass or 316 stainless steel.
<b>VALVE NEEDLE</b>	316 stainless steel.
<b>ORIFICE</b>	316 stainless steel with PTFE liner.
<b>O-RINGS</b>	Buna-N® (brass valves). Viton® (stainless valves).

*\*\*The selection of materials of construction, is the responsibility of the customer. The company accepts no liability.*

### ORDERING INFORMATION BARSTOCK METERING VALVES MFV™

MODEL NUMBER	FLOW PATTERN	MATERIAL	MAXIMUM FLOW [mL/min]		ORIFICE [in]	CV
			Air	Water		
VM1-BB-1A	Straight	Brass	200	6	0.042	0.0005
VM2-BB-1A	Straight	Brass	400	12	0.042	0.001
VM3-BB-1A	Straight	Brass	1000	30	0.042	0.0025
VM4-BB-1A	Straight	Brass	2500	70	0.093	0.0061
VM5-BB-1A	Straight	Brass	6200	200	0.093	0.016
VM6-BB-1A	Straight	Brass	21500	650	0.093	0.054
VM1-SV-2A	Straight	Stainless	200	6	0.042	0.0005
VM2-SV-2A	Straight	Stainless	400	12	0.042	0.001
VM3-SV-2A	Straight	Stainless	1000	30	0.042	0.0025
VM4-SV-2A	Straight	Stainless	2500	70	0.093	0.0061
VM5-SV-2A	Straight	Stainless	6200	200	0.093	0.016
VM6-SV-2A	Straight	Stainless	21500	650	0.093	0.054
VM1-BB-6A	90 degree	Brass	200	6	0.042	0.0005
VM2-BB-6A	90 degree	Brass	400	12	0.042	0.001
VM3-BB-6A	90 degree	Brass	1000	30	0.042	0.0025
VM4-BB-6A	90 degree	Brass	2500	70	0.093	0.0061
VM5-BB-6A	90 degree	Brass	6200	200	0.093	0.016
VM6-BB-6A	90 degree	Brass	21500	650	0.093	0.054
VM1-SV-7A	90 degree	Stainless	200	6	0.042	0.0005
VM2-SV-7A	90 degree	Stainless	400	12	0.042	0.001
VM3-SV-7A	90 degree	Stainless	1000	30	0.042	0.0025
VM4-SV-7A	90 degree	Stainless	2500	70	0.093	0.0061
VM5-SV-7A	90 degree	Stainless	6200	200	0.093	0.016
VM6-SV-7A	90 degree	Stainless	21500	650	0.093	0.054

Note: Based on 10psig(69 kPa) inlet pressure and atmospheric exhaust.



Designed for controlling a broad range of flow rates of liquids and gases, CV™ Utility valves are available in three conveniently overlapping orifice-needle sizes.

**BARSTOCK \ UTILITY VALVES CV™**

These versatile, rugged and reliable valves are suitable for laboratory instrumentation, bench top or OEM flow control purposes.



CV™ Valve-Straight Flow

CV™ Valve-90 deg Flow

**SPECIFICATIONS**

<b>MAXIMUM PRESSURE</b>	500 psig (3792 kPa).
<b>MAXIMUM TEMPERATURE</b>	180 °F (82 °C) - (brass valves). 250 °F (121 °C) - (stainless valves).

**\*\*MATERIALS OF CONSTRUCTION**

<b>CONNECTIONS</b>	1/8" female NPT.
<b>O-RINGS</b>	PTFE and Buna-N® (brass valves). PTFE and Viton® (stainless valves).

Valves are offered in straight (T) and 90 degree (L) flow patterns. All valves are supplied with 1/8" FNPT inlet and outlet ports.

Valve cartridges are also interchangeable with built-in valves of Aalborg's series of P, T, S, and G flow meter product line.

The valve body is precision machined chrome plated brass or type 316 stainless steel.

*\*\*The selection of materials of construction, is the responsibility of the customer. The company accepts no liability.*

**design features**

- ✓ Bubble tight shutoff.
- ✓ Straight or 90 degree flow patterns.
- ✓ Brass or 316 stainless steel.

**ORDERING INFORMATION BARSTOCK UTILITY VALVES CV™**

MODEL NUMBER	FLOW PATTERN	MATERIAL	MAXIMUM FLOW [mL/min]		ORIFICE [in]	Cv
			Air	Water		
VCL-BB-1A	Straight	Brass	5000	350	0.052	0.03
VCL-SV-2A	Straight	Stainless	5000	350	0.052	0.03
VCL-BB-6A	90 degree	Brass	5000	350	0.052	0.03
VCL-SV-7A	90 degree	Stainless	5000	350	0.052	0.03
VCM-BB-1A	Straight	Brass	20000	1200	0.082	0.10
VCM-SV-2A	Straight	Stainless	20000	1200	0.082	0.10
VCM-BB-6A	90 degree	Brass	20000	1200	0.082	0.10
VCM-SV-7A	90 degree	Stainless	20000	1200	0.082	0.10
VCH-BB-1A	Straight	Brass	60000	3500	0.120	0.30
VCH-SV-2A	Straight	Stainless	60000	3500	0.120	0.30
VCH-BB-6A	90 degree	Brass	60000	3500	0.120	0.30
VCH-SV-7A	90 degree	Stainless	60000	3500	0.120	0.30

Note: Based on 10psig (69 kPa) inlet pressure and atmospheric exhaust.

These compact and reliable PTFE needle valves are designed for laboratory and industrial applications for regulating corrosive gases and liquids or for high purity service. They may also be used as shut off valves.

Pliant PTFE bodies of the valves are reinforced by structurally rigid metallic shells. Fluids contact only PTFE and PCTFE materials. Shells are made of anodized aluminum or type 316 stainless steel and bushings are made of plated brass or 316 stainless steel. Where externally corrosive conditions exist stainless steel is recommended.

Valve spindles are made of rigid PCTFE to minimize the undesirable material "creeping" normally associated with PTFE.

**PTFE valves are designed for relatively high flow ranges while still performing well in low flow rates.**

Valves may be used in pressure or non-critical vacuum service.

The simplicity of design - there are only seven components (including a single PTFE o-ring) - assures reliability and minimizes sources of leakage. It takes seconds to disassemble the valve for cleaning and maintenance. The PTFE o-ring is radially compressed and due to this unique design feature the degree of compression may be adjusted without disassembly by tightening the hexagonal bushing.

## design features

- ✓ Fluids contact PTFE and PCTFE only.
- ✓ Structurally Rigid Metal Shell.
- ✓ One PTFE o-ring.
- ✓ Simplicity only seven components.

Note: Based on 10psig (69 kPa) inlet pressure and atmospheric exhaust.



PTFE Needle valve with Stainless Shell and FNPT Fittings

### ORDERING INFORMATION PTFE NEEDLE VALVES

MODEL NUMBER	MAXIMUM FLOW (ml/min)		CV	NON WETTED MATERIALS		CONNECTIONS
	AIR	WATER		SHELL	BUSHING	
VCL-TT-0A	2400	130	0.011	Aluminum	Brass	1/8" FNPT
VCH-TT-0A	55000	2800	0.250	Aluminum	Brass	1/8" FNPT
VCL-TT-0F	2400	130	0.011	Aluminum	Brass	1/4" Comp
VCH-TT-0F	55000	2800	0.250	Aluminum	Brass	1/4" Comp
VCL-TT-0G	2400	130	0.011	Aluminum	Brass	Glass Nipples
VCH-TT-0G	55000	2800	0.250	Aluminum	Brass	Glass Nipples
VCL-TT-2A	2400	130	0.011	Stainless	Stainless	1/8" FNPT
VCH-TT-2A	55000	2800	0.250	Stainless	Stainless	1/8" FNPT
VCL-TT-2F	2400	130	0.011	Stainless	Stainless	1/4" Comp
VCH-TT-2F	55000	2800	0.250	Stainless	Stainless	1/4" Comp
VCL-TT-2G	2400	130	0.011	Stainless	Stainless	Glass Nipples
VCH-TT-2G	55000	2800	0.250	Stainless	Stainless	Glass Nipples

### SPECIFICATIONS

<b>MAXIMUM PRESSURE</b>	75 psig (517 kPa)
<b>MAXIMUM TEMPERATURE</b>	150 °F (65 °C)
<b>ORIFICE SIZE</b>	0.125" diameter (3.175 mm)
<b>**MATERIALS OF CONSTRUCTION FLUID CONTACTING</b>	Body and o-ring-PTFE. Valve spindle-PCTFE.
<b>NON FLUID CONTACTING</b>	Shell - Aluminum (anodized) or 316 stainless steel. Bushing plated brass, or 316 stainless steel. Adjusting Knob-phenolic.

\*\*The selection of materials of construction, is the responsibility of the customer. The company accepts no liability.

**MVT™ Metering valves are constructed of PTFE and PCTFE materials.**

Non-fluid contacting external parts are made of anodized aluminum.

Valves are offered in three conveniently overlapping flow ranges. Safety handle prevents over tightening and facilitates fine metered regulation. MVT™ valves are useful in regulating the flow of corrosive gases and liquids.

**They may be used in pressure or non-critical vacuum service and serve as bubble tight shutoff valves.**



PTFE Needle valve with Aluminum Shell and Glass Nipples



PTFE Metering Valve

**ORDERING INFORMATION PTFE METERING VALVE**

MODEL NUMBER	MAXIMUM FLOW [mL/min]		Cv	CONNECTIONS
	Air	Water		
VM1-TT-0A	600	36	0.003	1/8" FNPT
VM3-TT-0A	3000	180	0.015	1/8" FNPT
VM6-TT-0A	30000	1800	0.150	1/8" FNPT
VM1-TT-0F	600	36	0.003	1/4" Comp.
VM3-TT-0F	3000	180	0.015	1/4" Comp.
VM6-TT-0F	30000	1800	0.150	1/4" Comp.
VM1-TT-0G	600	36	0.003	Glass Nipples
VM3-TT-0G	3000	180	0.015	Glass Nipples
VM6-TT-0G	30000	1800	0.150	Glass Nipples

**SPECIFICATIONS**

<b>MAXIMUM PRESSURE</b>	75 psig (517 kPa)
<b>MAXIMUM TEMPERATURE</b>	150 °F (65 °C)
<b>ORIFICE SIZE</b>	0.125" diameter (3.175 mm)
<b>NUMBER OF TURNS TO FULLY OPEN</b>	Eight.
<b>STEM</b>	Non-rising type.
<b>FLUID CONTACTING COMPONENTS</b>	Body /o-ring-PTFE. Valve spindle-PCTFE.
<b>NON-FLUID CONTACTING COMPONENTS</b>	Shell + Handle - Aluminum (anodized).

\* Based on 10 psig (69 kPa) inlet pressure and atmospheric exhaust.

### design features

- ✓ Fluids contact PTFE and PCTFE only.
- ✓ One PTFE o-ring.
- ✓ Simplicity, only six components.

**PTFE needle valves are designed for laboratory and industrial applications for regulating corrosive gases and liquids or for high purity service. They may also be used as shut off valves.**

Fluids contact only PTFE and PCTFE materials. Bushings are made of 316 stainless steel.

**Valve spindles are made of rigid PCTFE to minimize the undesirable material “creeping” normally associated with PTFE.**

PTFE valves are designed for relatively high flow ranges while still performing well in low flow rates.

**Valves may be used in pressure or non-critical vacuum service.**

The simplicity of design - there are only six components (including a single PTFE o-ring) - assures reliability and minimizes sources of leakage. It takes seconds to disassemble the valve for cleaning and maintenance.

**The PTFE o-ring is radially compressed and due to this unique design feature the degree of compression may be adjusted without disassembly by tightening the bushing.**

*\*\*The selection of materials of construction, is the responsibility of the customer. The company accepts no liability.*



6mm PTFE Needle Valves

### ORDERING INFORMATION FOR 6mm PTFE NEEDLE VALVES

MODEL NUMBER	MAXIMUM FLOW LPM		CV	CONNECTIONS
	AIR	WATER		
VTF-TT-0A	300	9	0.765	3/8" FNPT

Note: Based on 10psig(69 kPa) inlet pressure and atmospheric exhaust.

### SPECIFICATIONS

<b>MAXIMUM PRESSURE</b>	75 psig (517 kPa)
<b>MAXIMUM TEMPERATURE</b>	150 °F (65 °C)
<b>ORIFICE SIZE</b>	6.0 mm (0.250") diameter.
<b>**MATERIALS OF CONSTRUCTION FLUID CONTACTING</b>	Body and o-ring-PTFE. Valve spindle-PCTFE.
<b>NON FLUID CONTACTING</b>	Bushings 316 stainless steel. Mounting Nut and Adjusting Knob Delrin.



## FLOW CAPACITIES Spare valve cartridges P, Px and S meters

TABLE 1 - MFV™ VALVE FLOW CAPACITIES 10 psig (0.7 kPa gauge) INLET PRESSURE, ATMOSPHERIC EXHAUST

SIZE	AIR		HELIUM		WATER	
	[mL/min]	[scfh]	[mL/min]	[scfh]	[mL/min]	[gph]
1	200	0.42	400	0.85	6	0.095
2	400	0.85	850	1.80	12	0.190
3	1020	2.15	2100	4.45	28	0.444
4	2600	5.50	6050	12.80	85	1.347
5	8900	18.85	20800	44.05	270	4.279
6	35000	74.15	84500	179.10	1070	16.960
7	63000	133.50	156000	330.50	1930	30.590



TABLE 2 - CV™ VALVE FLOW CAPACITIES 10 psig (0.7 kPa gauge) INLET PRESSURE, ATMOSPHERIC EXHAUST

SIZE	AIR		HELIUM		WATER	
	[mL/min]	[scfh]	[mL/min]	[scfh]	[mL/min]	[gph]
L	5050	10.70	11500	24.35	360	5.70
M	30000	63.55	71500	151.50	1760	27.90
H	76000	161.05	180000	381.40	4500	71.33



## FLOW CAPACITIES Spare valve cartridges T and Tx meters

TABLE 1a - MVT™ VALVE FLOW CAPACITIES 10 psig (0.7 kPa gauge) INLET PRESSURE, ATMOSPHERIC EXHAUST

SIZE	AIR		HELIUM		WATER	
	[mL/min]	[scfh]	[mL/min]	[scfh]	[mL/min]	[gph]
1	600	1.25	1250	2.65	36	0.57
2	3000	6.35	6900	14.60	180	2.85
3	30000	63.55	71500	151.50	1800	28.53



TABLE 2a - CVT™ VALVE FLOW CAPACITIES 10 psig (0.7 kPa gauge) INLET PRESSURE, ATMOSPHERIC EXHAUST

SIZE	AIR		HELIUM		WATER	
	[mL/min]	[scfh]	[mL/min]	[scfh]	[mL/min]	[gph]
L	2400	5.10	5300	11.23	130	2.05
H	55000	116.55	135000	286.05	2800	44.40

## METER SIZING FOR P, Px, T, Tx AND S METERS

Flow capacity tables 6, 7, 8, 9 and 10 (pages 43 to 46) are based on calibrations at standard conditions, meaning 14.7 psia (1 atm) pressure and 70 °F (21.1 °C).

Tables list maximum flow rates of flow tubes. The usable range of meters is at least 10:1, often more. Thus, as a rule of thumb, to estimate the minimum metering limit divide the flow rates listed, by ten.

For gases or liquids with fluid properties not greatly different from the calibration media, tables apply directly, when working pressure and temperature are also approximately standard.

Where the above conditions do not apply the maximum flow rates of the metered fluids are converted to equivalent standard flow rates of air or water.

To do this calculate “K” as shown in charts, multiply the maximum flow rate with this factor, and select the appropriate flow tube size from the Flow Capacity tables 6, 7, 8, 9 and 10 (pages 43 to 46).

### gas flow

$$Q_{air} = K_{gas} \times Q_{gas}$$

$$K_{gas} = \sqrt{G \times \frac{T_{act}}{T_o} \times \frac{P_o}{P_{act}}}$$

#### where:

- $Q_{air}$  = equivalent air flow capacity at Standard Conditions (SPT).
- $Q_{gas}$  = maximum flow of metered gas.
- $G$  = specific gravity of metered gas (from table 5).
- $T_{act}$  = absolute temperature at flow condition, deg R or deg K.
- $T_o$  = absolute temperature at Standard Conditions. (STP) deg R (530) or deg K (294).
- $P_{act}$  = pressure at flow conditions, psia.
- $P_o$  = pressure at Standard Conditions (STP), (14.7 psia).

### liquid flow

$$Q_{water} = K_{liq} \times Q_{liq}$$

$$K_{liq} = \sqrt{\frac{(d_f - d_w)}{(d_f - d_L)} \times \frac{d_L}{d_w}}$$

#### where:

- $Q_{water}$  = equivalent water flow capacity at Standard Conditions (STP).
- $Q_{liq}$  = maximum flow of metered liquid.
- $d_f$  = density of float selected, (see table 3), (g/ml).
- $d_L$  = density of metered liquid, (g/ml).
- $d_w$  = density of water at Standard Conditions (STP) (1.0 g/ml).

## CALCULATION VS. CALIBRATION FOR P, Px, S, T and Tx METERS

In case of liquid flows at each major point along the scale, sample volumes are collected in a buret of a volumetric flask during measured time intervals. Volumes are interpolated to a unit of time such as for example [mL/min] or [cu. ft/hr] etc. A table or a graph is then constructed to establish a complete set of calibration data. In case of gas flows, calibration data can be similarly developed, except that collection of sample volumes is accomplished by means of gas sampling devices, the simplest of which is a “soap bubble” meter.

It is very important that the correction factors as calculated from the accompanying equations are used for sizing only. These relationships are greatly simplified and will not provide precise predictable flow corrections. It is always best practice to calibrate meters for non-standard conditions on site, by using reliable means of calibration.

**TABLE 3 - FLOAT DENSITIES**

MATERIAL	DENSITY [g/ml]
GLASS	2.53
SAPPHIRE	3.98
STAINLESS STEEL	8.04
CARBOLOY	14.98
TANTALUM	16.58

**TABLE 4 - CONVERSION FACTORS**

MULTIPLY	BY	TO OBTAIN
atm	14.70	lbs/sq. in.
atm	1.0333	kg/sq. cm.
lbs/square inch	0.07031	kg/sq. cm.
ml/min	0.001	liters/min.
ml/min	$3.531 \times 10^{-5}$	cu. ft/min.
ml/min	$1.585 \times 10^{-2}$	gal/hr.
cubic ft/hr	472	ml/min.
gal/min	3785	ml/min.
g/ml	62.43	lbs/cu. ft.
g/ml	0.03613	lbs/cu. in.
cc/min	1	ml/min.
cfm (ft <sup>3</sup> /min)	28.31	L/min.
cfm (ft <sup>3</sup> /min)	1.693	m <sup>3</sup> /hr.
oz/min	29.57	ml/min.

**PRESSURE**

MULTIPLY	BY	TO OBTAIN
PSI	27.71	in. H <sub>2</sub> O
PSI	2.036	in. Hg
PSI	703.1	mm/H <sub>2</sub> O
PSI	51.75	mm/Hg
PSI	.0703	kg/cm <sup>2</sup>
PSI	.0889	bar
PSI	68.95	mbar
PSI	6895	Pa
PSI	6.895	kPa

**TEMPERATURE**

$^{\circ}\text{F} = (1.8 \times ^{\circ}\text{C}) + 32$   
 $^{\circ}\text{C} = (^{\circ}\text{F} - 32) \times 0.555$   
 $^{\circ}\text{Kelvin} = ^{\circ}\text{C} + 273.2$

**LENGTH**

MULTIPLY	BY	TO OBTAIN
Multiply	2.54	cm
Inch	12	inch
FL	0.305	meter
Yard	1.094	meter
Angstrom	$10^{10}$	meter

**TABLE 5- DENSITY, VISCOSITY & SPECIFIC GRAVITY OF GASES**

GAS	DENSITY [g/ml]	VISCOSITY [centipols]	SPECIFIC GRAVITY G [air=1.0]
Acetylene	0.001090	0.00988	0.9073
Air	0.001200	0.01812	1.0000
Ammonia	0.000716	0.00994	0.5963
Argon	0.001660	0.02220	1.3796
Butane	0.002484	0.00848	2.0854
Carbon Dioxide	0.001835	0.01470	1.5290
Carbon Monoxide	0.001163	0.01750	0.9671
Chlorine	0.002983	0.01330	2.4860
Ethane	0.001260	0.00901	1.0493
Ethylene	0.001170	0.00994	0.9749
Helium	0.0001656	0.01980	0.13804
Hydrogen	0.0000834	0.00885	0.06952
Hydrogen Chloride	0.001512	0.01560	1.2678
Methane	0.0006653	0.01099	0.5544
Nitrogen	0.001160	0.01756	0.96724
Nitrous Oxide	0.001833	0.01453	1.5297
Oxygen	0.001326	0.02030	1.10527
Propane	0.001874	0.00805	1.5620
Sulfur Dioxide	0.002717	0.01270	2.2638

## TABLES OF STANDARD FLOW CAPACITIES P, Px, T, Tx AND S METERS

TABLE 6 150mm Flow tubes (See Table B for Gas Flow Capacities)				
FLOW TUBE NUMBER	FLOW TUBE MAXIMUM FLOW RATE			
	AIR		WATER	
	[mL/min]	[scfh]	[mL/min]	[gph]
042-15-GL	19	0.040	0.19	0.003
042-15-SA	30	0.064	0.39	0.006
042-15-ST	61	0.128	0.94	0.015
042-15-CA	110	0.234	1.91	0.030
042-15-TA	121	0.257	2.13	0.033
032-41-GL	49	0.104	0.49	0.008
032-41-SA	73	0.166	0.96	0.016
032-41-ST	143	0.290	2.34	0.039
032-41-CA	246	0.521	4.7	0.073
032-41-TA	264	0.559	5.1	0.087
062-01-GL	92	0.195	0.9	0.013
062-01-SA	141	0.297	1.9	0.030
062-01-ST	264	0.559	4.7	0.075
062-01-CA	444	0.962	8.5	0.135
062-01-TA	484	1.025	9.2	0.146
112-02-GL	374	0.792	5.5	0.087
112-02-SA	513	1.087	10.0	0.159
112-02-ST	814	1.725	20.4	0.323
112-02-CA	1222	2.589	33.7	0.534
112-02-TA	1331	2.820	36.1	0.572
082-03-GL	344	1.748	18.5	0.262
082-03-SA	1093	2.316	26.1	0.414
082-03-ST	1682	3.564	44.6	0.729
082-03-CA	2423	5.133	70.5	1.117
082-03-TA	2576	5.458	75.6	1.198
092-04-GL	2313	4.900	54	0.848
092-04-SA	3079	6.523	76	1.233
092-04-ST	4562	9.665	133	2.067
092-04-CA	6621	14.02	201	3.180
092-04-TA	6932	14.88	212	3.357
102-05-GL	3922	8.07	64	1.336
102-05-SA	5188	10.60	126	2.002
102-05-ST	7825	16.08	217	3.433
102-05-CA	11371	22.94	329	5.219
102-05-TA	11965	24.10	353	5.589
034-39-GL	8505	18.38	210	3.32
034-39-SA	11357	24.05	306	4.84
034-39-ST	16737	35.46	506	8.02
034-39-CA	23752	50.32	747	11.84
034-39-TA	25252	53.50	790	12.52
044-40-GL	23742	47.7	541	8.58
044-40-SA	30711	62.6	806	12.77
044-40-ST	45227	87.9	1288	20.41
044-40-CA	66346	126.0	1881	29.81
044-40-TA	69940	132.6	2001	31.72

TABLE 7 65mm Flow tubes (See Table B for Gas Flow Capacities)				
FLOW TUBE NUMBER	FLOW TUBE MAXIMUM FLOW RATE			
	AIR		WATER	
	[mL/min]	[scfh]	[mL/min]	[gph]
042-07-GL	6	0.013	0.07	0.001
042-07-SA	9	0.017	0.08	0.001
042-07-ST	19	0.036	0.28	0.004
042-07-CA	33	0.070	0.62	0.009
042-07-TA	36	0.072	0.66	0.010
032-15-GL	49	0.104	0.55	0.009
032-15-SA	74	0.153	0.96	0.016
032-15-ST	145	0.307	2.38	0.038
032-15-CA	246	0.528	4.60	0.073
032-15-TA	271	0.578	5.25	0.084
022-13-GL	104	0.220	1.8	0.028
022-13-SA	159	0.337	3.4	0.054
022-13-ST	299	0.633	5.8	0.122
022-13-CA	516	1.093	14.1	0.223
022-13-TA	530	1.123	15.5	0.246
012-10-GL	202	0.43	2.6	0.041
012-10-SA	300	0.64	4.7	0.074
012-10-ST	522	1.11	12.0	0.190
012-10-CA	818	1.73	20.8	0.330
012-10-TA	859	1.82	23.5	0.372
052-01-GL	966	2.09	20.5	0.325
052-01-SA	1299	2.75	34.0	0.539
052-01-ST	1946	4.12	55.6	0.881
052-01-CA	2827	5.99	88.5	1.403
052-01-TA	3020	6.40	94.0	1.490
023-92-GL	1249	2.65	25	0.428
023-92-SA	1623	3.44	37	0.586
023-92-ST	2520	5.34	71	1.125
023-92-CA	3630	7.80	104	1.648
013-88-GL	2040	4.32	40	0.63
013-88-SA	2704	5.73	61	0.97
013-88-ST	3990	8.45	108	1.71
013-88-CA	5739	12.16	170	2.69
365-02-GL	2678	5.67	52	0.82
365-02-ST	4922	10.40	150	2.38
014-96-GL	6318	13.4	147	2.33
014-96-SA	8145	17.3	217	3.44
014-96-ST	12068	25.5	364	5.77
014-96-CA	17153	36.3	540	8.56
014-96-TA	18213	38.6	568	9.00
054-17-GL	13153	27.9	309	4.90
054-17-SA	16980	36.0	456	7.23
054-17-ST	24680	52.3	745	11.8
054-17-CA	35320	74.8	1110	17.59
054-17-TA	37589	79.6	1182	18.73
064-63-GL	23169	49.1	522	8.27
064-63-SA	29218	61.9	798	12.65
064-63-ST	42094	89.2	1261	19.97
064-63-CA	58500	123.9	1866	29.58
064-63-TA	62100	131.6	2027	32.13

\*SUFFIX REFERS TO FLOAT MATERIALS;

- GL = Black Glass
- SA = Sapphire (red)
- ST = 316 Stainless Steel
- CA = Carboloy®
- TA = Tantalum



**TABLE OF STANDARD FLOW CAPACITIES P, Px, T, Tx AND S METERS**

**TABLE 6 - 150mm FLOW TUBES, GAS FLOW CAPACITIES OF ROUTINE GASES**

<b>FLOW TUBE MAXIMUM FLOW RATES</b>												
FLOW TUBE NUMBER	ARGON		CARBON DIOXIDE		HELIUM		HYDROGEN		NITROGEN		OXYGEN	
	[mL/min]	[scfh]	[mL/min]	[scfh]	[mL/min]	[scfh]	[mL/min]	[scfh]	[mL/min]	[scfh]	[mL/min]	[scfh]
042-15-GL	15	0.033	23	0.050	16	0.034	37	0.078	20	0.041	17	0.036
042-15-SA	24	0.052	37	0.078	26	0.054	59	0.126	31	0.066	27	0.057
042-15-ST	49	0.104	72	0.153	53	0.112	123	0.260	62	0.132	54	0.115
042-15-CA	90	0.192	127	0.269	101	0.214	232	0.491	114	0.241	99	0.210
042-15-TA	99	0.211	139	0.294	112	0.236	256	0.543	125	0.265	109	0.231
032-41-GL	44	0.093	56	0.121	46	0.100	94	0.212	48	0.119	42	0.104
032-41-SA	60	0.127	84	0.178	69	0.148	149	0.318	76	0.161	70.4	0.149
032-41-ST	113	0.239	150	0.318	133	0.282	301	0.646	143	0.303	131	0.278
032-41-CA	202	0.428	251	0.532	260	0.551	567	1.258	255	0.540	228	0.483
032-41-TA	222	0.470	263	0.557	288	0.610	602	1.390	274	0.581	244	0.517
062-01-GL	76	0.161	103	0.218	96	0.191	208	0.441	92	0.195	81	0.172
062-01-SA	111	0.235	157	0.333	142	0.301	322	0.682	139	0.294	121	0.256
062-01-ST	218	0.462	281	0.595	263	0.600	627	1.328	271	0.574	233	0.494
062-01-CA	373	0.790	445	0.943	519	1.100	1120	2.373	462	0.970	407	0.862
062-01-TA	393	0.833	470	0.996	555	1.176	1225	2.596	495	1.049	433	0.917
112-02-GL	305	0.646	355	0.752	450	0.953	1021	2.183	382	0.809	340	0.720
112-02-SA	429	0.909	472	1.000	681	1.443	1497	3.172	520	1.102	472	1.000
112-02-ST	676	1.432	728	1.542	1290	2.733	2496	5.288	824	1.746	753	1.595
112-02-CA	1020	2.161	1072	2.271	2221	4.706	3876	8.212	1220	2.585	1131	2.396
112-02-TA	1085	2.299	1134	2.403	2356	4.992	4257	9.019	1310	2.775	1206	2.555
082-03-GL	687	1.46	725	1.54	1490	3.16	2620	5.55	827	1.75	772	1.64
082-03-SA	910	1.93	944	2.00	2059	4.36	3546	7.51	1110	2.35	1024	2.18
082-03-ST	1380	2.92	1420	3.01	3397	7.20	5547	11.75	1662	3.52	1545	3.27
082-03-CA	1996	4.23	2039	4.32	5120	10.85	8170	17.31	2405	5.10	2246	4.78
082-03-TA	2131	4.51	2163	4.58	5437	11.52	8717	18.47	2575	5.46	2364	5.01
092-04-GL	1949	4.13	2048	4.34	4880	10.34	7817	16.56	2395	5.07	2169	4.60
092-04-SA	2605	5.52	2620	5.56	6458	13.68	10455	22.15	3142	6.86	2860	6.06
092-04-ST	3903	8.27	3990	8.45	9770	20.70	15855	33.59	4685	9.93	4341	9.20
092-04-CA	5665	12.00	5743	12.17	14500	30.72	22790	48.28	6845	14.50	6307	13.36
092-04-TA	6040	12.80	6018	12.75	15420	32.67	24252	51.38	7080	15.00	6690	14.17
102-05-GL	3151	6.68	3374	7.15	7893	16.53	13105	27.78	3868	8.19	3485	7.38
102-05-SA	4175	8.85	4388	9.30	10336	21.89	16108	34.13	5090	10.78	4652	9.86
102-05-ST	6384	13.54	6308	13.36	15060	33.82	27804	58.91	7722	16.36	6992	14.81
102-05-CA	9069	19.21	9069	19.21	23509	49.81	37553	79.57	10973	23.25	10082	21.36
102-05-TA	9627	20.40	9475	20.07	25131	53.24	39998	84.74	11628	24.64	10741	22.76
034-39-GL	7366	15.61	7485	15.86	19426	41.16	29840	63.22	8916	18.89	8269	17.52
034-39-SA	9539	20.21	9557	20.25	25400	53.81	40006	84.78	11524	24.42	10706	22.68
034-39-ST	14131	29.94	14051	29.77	38576	81.73	59996	127.1	17021	36.06	15710	33.28
034-39-CA	20166	42.72	19854	42.06	56220	119.1	83052	175.9	24071	51.00	22432	47.53
034-39-TA	21414	45.37	21115	44.74	60596	128.3	90410	191.5	25709	54.47	23790	50.40
044-40-GL	19761	41.9	18989	40.2	53100	112.5	85812	181.8	23512	49.8	21350	45.2
044-40-SA	24563	52.0	23855	50.6	70100	148.5	110100	233.2	29930	63.4	27181	57.5
044-40-ST	35300	74.8	34287	72.6	103647	219.8	159699	338.3	43000	91.1	39567	83.8
044-40-CA	47890	101.4	46311	98.1	146500	310.4	221872	470.0	59580	126.2	54902	116.3
044-40-TA	51997	110.2	49009	103.8	189826	402.2	284423	496.6	68826	135.2	57960	122.8

\*Suffix refers to float materials: G = black glass, S = sapphire (red), ST = 316 stainless steel, C = Carboloy®, T = tantalum.

Flow capacities shown in Tables 4, 5, 6 and 7 are based on calibrations at standard (STP) conditions (70 °F /21.1 °C and 14.7psia/1 atm abs). For fluids other than air or water at STP conditions see paragraph on **METER SIZING** on page 41. For special OEM requirements call toll free 1-800-866-3837.

for direct reading (engineering units) scale flow tubes contact the company or visit us at [www.aalborg.com](http://www.aalborg.com)

## TABLE OF STANDARD FLOW CAPACITIES P, Px, T, Tx AND S METERS

TABLE 9 - 65mm FLOW TUBES, GAS FLOW CAPACITIES OF ROUTINE GASES

### FLOW TUBE MAXIMUM FLOW RATES

FLOW TUBE NUMBER	ARGON		CARBON DIOXIDE		HELIUM		HYDROGEN		NITROGEN		OXYGEN	
	[mL/min]	[scfh]	[mL/min]	[scfh]	[mL/min]	[scfh]	[mL/min]	[scfh]	[mL/min]	[scfh]	[mL/min]	[scfh]
042-07-GL	4	0.01	6.5	0.01	5.5	0.01	9.6	0.02	5.6	0.01	5	0.01
042-07-SA	7.7	0.02	10	0.02	8	0.02	15.3	0.03	8.5	0.02	7	0.01
042-07-ST	14	0.03	20	0.04	16	0.03	32.3	0.07	18	0.04	15	0.03
042-07-CA	28	0.06	39	0.08	30	0.06	53.6	0.11	34	0.07	29	0.06
042-07-TA	29	0.06	40	0.08	32	0.07	64.8	0.14	34	0.07	30	0.06
032-15-GL	38	0.08	59	0.13	47	0.10	100	0.21	51	0.11	46	0.10
032-15-SA	63	0.13	90	0.19	71	0.15	150	0.32	78	0.17	72	0.15
032-15-ST	122	0.26	160	0.34	146	0.31	314	0.67	149	0.32	132	0.28
032-15-CA	214	0.45	263	0.56	274	0.58	593	1.26	264	0.56	239	0.51
032-15-TA	224	0.47	279	0.59	294	0.62	654	1.39	276	0.58	248	0.53
022-13-GL	86	0.18	122	0.26	99	0.21	284	0.60	113	0.24	94	0.20
022-13-SA	131	0.28	181	0.38	157	0.33	435	0.92	167	0.35	147	0.31
022-13-ST	246	0.52	310	0.66	313	0.66	700	1.75	312	0.66	268	0.57
022-13-CA	420	0.89	494	1.05	604	1.28	1500	3.18	524	1.11	456	0.97
022-13-TA	446	0.94	519	1.10	632	1.34	1553	3.29	563	1.19	486	1.03
012-10-GL	174	0.37	221	0.47	211	0.45	502	1.06	215	0.46	189	0.40
012-10-SA	257	0.54	307	0.65	327	0.69	788	1.67	312	0.66	279	0.59
012-10-ST	429	0.91	489	1.04	636	1.35	1488	3.15	530	1.12	480	1.02
012-10-CA	685	1.45	735	1.56	1185	2.51	2455	5.20	838	1.78	761	1.61
012-10-TA	724	1.53	775	1.64	1300	2.75	2728	5.78	877	1.86	800	1.69
052-01-GL	829	1.76	883	1.87	1903	4.03	3212	6.82	1015	2.15	970	2.06
052-01-SA	1095	2.32	1143	2.42	2606	5.52	4215	8.93	1321	2.80	1217	2.58
052-01-ST	1645	3.49	1699	3.60	4128	8.75	6598	13.98	1983	4.20	1842	3.90
052-01-CA	2415	5.12	2438	5.17	6175	13.08	9450	20.02	2900	6.14	2676	5.67
052-01-TA	2559	5.42	2587	5.48	6588	13.96	10332	21.89	3063	6.49	2837	6.01
023-92-GL	1065	2.26	1110	2.35	1990	4.22	3923	8.31	1293	2.74	1165	2.47
023-92-SA	1395	2.96	1500	3.18	2950	6.25	5258	11.14	1710	3.62	1575	3.34
023-92-ST	2124	4.50	2190	4.64	4970	10.53	8602	18.22	2610	5.53	2360	5.00
023-92-CA	3125	6.62	3210	6.80	7675	16.26	12850	27.22	3820	8.09	3485	7.38
013-88-GL	1784	3.78	1794	3.80	3470	7.35	6359	13.47	2091	4.43	1928	4.08
013-88-SA	2279	4.83	2314	4.90	4932	10.45	9130	19.34	2859	6.06	2522	5.34
013-88-ST	3388	7.18	3449	7.31	8699	18.43	13600	28.81	4097	8.68	3761	7.97
013-88-CA	4904	10.39	4937	10.46	13227	28.02	19682	41.70	5928	12.56	5380	11.40
365-02-GL	2171	4.60	2237	4.74	4853	10.28	9410	19.94	2624	5.56	2323	4.92
365-02-ST	4172	8.84	4225	8.95	10947	23.19	16857	38.06	5026	10.65	4733	10.03
014-96-GL	5290	11.21	5470	11.59	13750	29.13	21712	46.00	6380	13.52	5880	124.5
014-96-SA	6900	14.62	6980	14.79	18500	39.19	28211	59.77	8280	17.54	7640	16.19
014-96-ST	10175	21.56	10150	21.50	27300	57.84	42040	89.07	12200	25.85	11250	23.83
014-96-CA	14150	29.98	14200	30.08	39500	83.69	58498	123.9	17050	36.12	15875	33.63
014-96-TA	15300	32.42	15050	31.89	41400	87.71	63804	135.1	18250	38.67	16700	35.38
054-17-GL	11125	23.57	11156	23.64	29762	63.1	47100	99.8	13412	28.42	12341	26.15
054-17-SA	14389	30.49	14256	30.20	38731	82.1	61715	130.7	17351	36.76	16047	34.00
054-17-ST	21116	44.74	20798	44.06	58472	123.8	90323	191.3	25311	53.63	23322	49.41
054-17-CA	30126	63.83	29156	61.77	84632	179.3	130805	277.1	35830	75.91	33287	70.52
054-17-TA	31622	67.00	31126	65.94	88862	188.2	139224	294.9	37724	79.92	35738	75.72
064-63-GL	19817	42.0	19379	41.1	51380	108.8	80752	171.0	23506	49.80	21686	45.9
064-63-SA	24597	52.1	24630	52.2	67754	143.5	106000	224.5	30337	64.27	27901	59.1
064-63-ST	37441	79.3	35100	74.4	104600	221.6	154750	327.8	43487	92.13	40053	84.9
064-63-CA	50200	106.3	47950	101.5	148114	313.8	220500	467.1	60618	128.4	55539	117.6
064-63-TA	52850	111.9	53200	112.7	156500	331.5	222300	470.9	64051	135.7	58300	123.5

**TABLE OF FLOW CAPACITIES at 50 PSIG for GAS PROPORTIONERS**

TABLE 10 - 150mm FLOW TUBES, GAS FLOW CAPACITIES FOR GAS PROPORTIONERS at 50 PSIG

FLOW TUBE MAXIMUM FLOW RATES							
FLOW TUBE NUMBER	AIR [mL/min]	ARGON [mL/min]	CARBON DIOXIDE [mL/min]	HELIUM [mL/min]	HYDROGEN [mL/min]	NITROGEN [mL/min]	OXYGEN [mL/min]
042-15-GL	83	67	97	73	169	85	74
042-15-SA	127	104	146	117	267	131	114
042-15-ST	242	200	265	241	535	249	218
042-15-CA	415	343	437	450	967	426	376
032-41-GL	191	161	195	203	399	197	166
032-41-SA	270	229	302	279	662	283	246
032-41-ST	460	383	574	478	1185	471	442
032-41-CA	743	625	1094	702	2013	771	719
062-01-GL	324	270	346	333	844	331	294
062-01-SA	505	412	494	569	1209	467	460
062-01-ST	825	687	771	1089	2432	833	764
062-01-CA	1275	1062	1132	1972	3732	1303	1175
112-02-GL	1086	855	934	1779	3110	1016	930
112-02-SA	1324	1115	1168	2468	4289	1340	1228
112-02-ST	2024	1717	1724	4083	6740	2034	1905
112-02-CA	2912	2472	2521	6927	9979	2997	2703
082-03-GL	2008	1697	1747	4214	6711	2039	1865
082-03-SA	2590	2186	2264	5656	8995	2643	2503
082-03-ST	3903	3274	3343	8669	14490	3731	3685
082-03-CA	5547	4697	4691	12717	19993	6169	5210
092-04-GL	5528	4794	4954	12540	18862	5801	5381
092-04-SA	7240	6163	6217	15703	25235	7415	6826
092-04-ST	10813	9077	9178	24629	38556	11044	10335
092-04-CA	15322	12904	12879	34709	55936	15433	14451
102-05-GL	9294	7705	7888	19830	30900	9419	8749
102-05-SA	11647	9969	10042	26008	45263	11955	11137
102-05-ST	17311	14489	14420	40831	60300	17525	16353
102-05-CA	24065	20744	20099	59702	86369	24549	22905
034-39-GL	19767	17978	17936	48193	73500	21676	19931
034-39-SA	27514	32001	54010	63240	97000	27449	25800
034-39-ST	38995	33778	33087	98676	142000	40086	36821
034-39-CA	55293	47151	45745	139847	200500	55930	52494
044-40-GL	49374	41899	40520	125617	182239	50258	46851
044-40-SA	62480	53038	51220	159976	231239	63595	59304
044-40-ST	89880	76322	73584	231946	333775	91478	85341
044-40-CA	123846	105182	101303	321265	460942	126041	117615

# TECHNICAL INFORMATION

## DIRECT READING SCALES FOR P, Px AND S METERS

TABLE 11 - FLOW TUBES FOR AIR							
65mm				150mm			
FLOW TUBE	QMAX	[UNITS]	PRESSURE	FLOW TUBE	QMAX	[UNITS]	PRESSURE
042-10-GL	7.00	mL/min	14.70 psia	042-12-SA	25.00	mL/min	14.70 psia
032-01-ST	50.00	mL/min	14.70 psia	032-06-SA	52.00	mL/min	14.70 psia
062-04-ST	75.00	mL/min	14.70 psia	042-06-CA	75.00	mL/min	14.70 psia
022-14-GL	100.00	mL/min	14.70 psia	032-10-ST	100.00	mL/min	14.70 psia
032-11-ST	130.00	mL/min	14.70 psia	042-75-CA	100.00	mL/min	14.70 psia
032-03-CA	250.00	mL/min	14.70 psia	032-21-ST	150.00	mL/min	14.70 psia
022-05-CA	500.00	mL/min	14.70 psia	062-03-ST	200.00	mL/min	14.70 psia
052-12-GL	1000.00	mL/min	14.70 psia	112-10-GL	300.00	mL/min	14.70 psia
052-04-GL	1.00	L/min	14.70 psia	112-08-SA	500.00	mL/min	14.70 psia
023-03-GL	1.15	L/min	14.70 psia	082-02-GL	800.00	mL/min	14.70 psia
052-07-ST	2.00	L/min	14.70 psia	112-19-CA	1.25	L/min	14.70 psia
013-89-ST	4.00	L/min	14.70 psia	082-12-ST	1.80	L/min	14.70 psia
014-03-GL	5.00	L/min	14.70 psia	092-25-GL	2.50	L/min	14.70 psia
014-02-ST	10.00	L/min	14.70 psia	102-07-GL	4.00	L/min	14.70 psia
044-11-ST	16.00	L/min	14.70 psia	102-03-SA	4.50	L/min	14.70 psia
054-01-ST	25.00	L/min	14.70 psia	092-14-ST	4.80	L/min	14.70 psia
064-03-ST	40.00	L/min	14.70 psia	102-01-SA	5.00	L/min	14.70 psia
052-05-GL	2.20	scfh	14.70 psia	034-62-GL	10.00	L/min	14.70 psia
365-18-GL	6.00	scfh	14.70 psia	102-16-CA	10.00	L/min	14.70 psia
365-19-ST	10.00	scfh	14.70 psia	034-13-ST	17.00	L/min	14.70 psia
034-61-ST	18.00	scfh	14.70 psia	044-14-GL	23.00	L/min	14.70 psia
014-17-ST	25.00	scfh	14.70 psia	044-41-ST	42.00	L/min	14.70 psia
054-02-ST	50.00	scfh	14.70 psia	044-16-CA	60.00	L/min	14.70 psia
064-62-ST	90.00	scfh	14.70 psia	112-01-CA	2.50	scfh	14.70 psia
074-02-CA	150.00	scfh	14.70 psia	092-09-GL	5.00	scfh	14.70 psia
014-01-CA	0.60	scfm	14.70 psia	102-06-GL	8.25	scfh	14.70 psia
				092-10-ST	10.00	scfh	14.70 psia
				102-08-ST	16.50	scfh	14.70 psia
				102-09-CA	23.00	scfh	14.70 psia
				044-05-GL	55.00	scfh	14.70 psia
				044-18-ST	90.00	scfh	14.70 psia
				044-07-ST	94.00	scfh	14.70 psia
				044-23-SA	1.00	scfm	14.70 psia
				044-43-ST	1.50	scfm	14.70 psia

TABLE 12 - FLOW TUBES FOR WATER							
65mm				150mm			
FLOW TUBE	QMAX	[UNITS]	PRESSURE	FLOW TUBE	QMAX	[UNITS]	PRESSURE
032-04-GL	0.50	mL/min	14.70 psia	032-05-SA	1.00	mL/min	14.70 psia
022-08-ST	6.00	mL/min	14.70 psia	112-12-SA	10.00	mL/min	14.70 psia
052-09-GL	25.00	mL/min	14.70 psia	112-05-ST	20.00	mL/min	14.70 psia
052-08-ST	60.00	mL/min	14.70 psia	092-02-GL	50.00	mL/min	14.70 psia
013-02-ST	115.00	mL/min	14.70 psia	092-08-GL	60.00	mL/min	14.70 psia
365-01-ST	150.00	mL/min	14.70 psia	102-11-GL	100.00	mL/min	14.70 psia
044-09-GL	250.00	mL/min	14.70 psia	092-06-CA	200.00	mL/min	14.70 psia
064-05-GL	500.00	mL/min	14.70 psia	044-15-ST	1.20	L/min	14.70 psia
054-03-ST	750.00	mL/min	14.70 psia	044-01-TA	2.00	L/min	14.70 psia
064-04-SA	1.00	L/min	14.70 psia	044-12-SA	0.22	gpm	14.70 psia
064-06-ST	1.20	L/min	14.70 psia	044-42-CA	0.45	gpm	14.70 psia
052-16-ST	3.00	L/hr	14.70 psia	044-10-CA	29.00	gph	14.70 psia
034-74-ST	2.7	gph	14.70 psia				
064-12-GL	10.00	gph	14.70 psia				
064-09-CA	24.00	gph	14.70 psia				
064-11-TA	32.00	gph	14.70 psia				

BULLETIN EM201007  
TECHNICAL INFORMATION

## DIRECT READING SCALES FOR P, Px AND S METERS

**TABLE 13 - FLOW TUBES FOR ARGON**

65mm				150mm			
FLOW TUBE	QMAX	[UNITS]	PRESSURE	FLOW TUBE	QMAX	[UNITS]	PRESSURE
052-15-SA	1000.00	mL/min	14.70 psia	062-10-CA	325.00	mL/min	14.70 psia
013-09-CA	4.5	L/min	14.70 psia	032-18-GL	33.00	mL/min	14.70 psia
064-14-SA	26.00	L/min	14.70 psia	082-11-CA	2.00	L/min	14.70 psia
023-05-GL	2.50	scfh	14.70 psia	034-07-ST	15.00	L/min	14.70 psia
365-17-ST	10.00	scfh	14.70 psia	044-22-SA	25.00	L/min	14.70 psia
014-14-ST	22.00	scfh	14.70 psia				
064-01-GL	50.00	scfh	14.70 psia				

**TABLE 14 - FLOW TUBES FOR CARBON DIOXIDE**

65mm				150mm			
FLOW TUBE	QMAX	[UNITS]	PRESSURE	FLOW TUBE	QMAX	[UNITS]	PRESSURE
042-20-SA	10.00	mL/min	14.70 psia	062-09-GL	100.00	mL/min	14.70 psia
042-09-ST	20.00	mL/min	14.70 psia	032-32-ST	150.00	mL/min	14.70 psia
032-20-GL	55.00	mL/min	14.70 psia	062-14-ST	300.00	mL/min	14.70 psia
022-24-SA	220.00	mL/min	14.70 psia	092-18-SA	2.5	L/min	14.70 psia
052-14-GL	1.00	L/min	14.70 psia	034-18-SA	10.00	L/min	14.70 psia
023-07-ST	2.00	L/min	14.70 psia				
014-18-GL	6.00	L/min	14.70 psia				
014-19-ST	10.00	L/min	14.70 psia				
064-08-ST	35.00	L/min	14.70 psia				

**TABLE 15 - DIRECT READING FLOW TUBES FOR FUEL OIL**

150mm			
FLOW TUBE	QMAX	[UNITS]	PRESSURE
034-60-GL	3.00	gph	14.70 psia

**TABLE 16 - DIRECT READING FLOW TUBES FOR HELIUM**

65mm				150mm			
FLOW TUBE	QMAX	[UNITS]	PRESSURE	FLOW TUBE	QMAX	[UNITS]	PRESSURE
032-07-SA	65.00	mL/min	14.70 psia	062-13-GL	100.00	mL/min	14.70 psia
022-02-GL	120.00	mL/min	14.70 psia	062-07-CA	500.00	mL/min	14.70 psia
014-04-GL	30.00	scfh	14.70 psia	082-05-GL	1500.00	mL/min	14.70 psia
				082-07-CA	5.00	L/min	14.70 psia
				034-09-ST	40.00	L/min	14.70 psia
				112-03-SA	1.25	scfh	14.70 psia

**TABLE 17 - DIRECT READING FLOW TUBES FOR HYDROGEN**

65mm				150mm			
FLOW TUBE	QMAX	[UNITS]	PRESSURE	FLOW TUBE	QMAX	[UNITS]	PRESSURE
032-13-GL	35.00	mL/min	14.70 psia	032-12-GL	100.00	mL/min	14.70 psia
042-01-ST	100.00	mL/min	14.70 psia	092-15-SA	20.00	scfh	14.70 psia
032-02-SA	150.00	mL/min	14.70 psia	044-20-SA	225.00	scfh	14.70 psia
012-01-GL	600.00	mL/min	14.70 psia				
022-01-CA	1.50	L/min	14.70 psia				
023-01-GL	3.50	L/min	14.70 psia				
013-01-GL	6.00	L/min	14.70 psia				
014-15-ST	42.00	L/min	14.70 psia				
013-08-ST	30.00	scfh	14.70 psia				

## DIRECT READING SCALES FOR P, P<sub>x</sub> AND S METERS

TABLE 18- DIRECT READING FLOW TUBES FOR METHANE			
150mm			
FLOW TUBE	QMAX	[UNITS]	PRESSURE
042-03-ST	40.00	mL/min	14.70 psia

TABLE 19- DIRECT READING FLOW TUBES FOR NITROUS OXIDE			
150mm			
FLOW TUBE	QMAX	[UNITS]	PRESSURE
112-11-SA	500.00	mL/min	14.70 psia

TABLE 20 - DIRECT READING FLOW TUBES FOR NITROGEN							
65mm				150mm			
FLOW TUBE	QMAX	[UNITS]	PRESSURE	FLOW TUBE	QMAX	[UNITS]	PRESSURE
042-08-GL	6.00	mL/min	14.70 psia	062-12-GL	100.00	mL/min	14.70 psia
032-16-ST	50.00	mL/min	14.70 psia	032-22-CA	200.00	mL/min	14.70 psia
032-08-SA	60.00	mL/min	14.70 psia	062-30-CA	300.00	mL/min	14.70 psia
022-15-GL	120.00	mL/min	14.70 psia	112-06-SA	500.00	mL/min	14.70 psia
022-06-SA	200.00	mL/min	14.70 psia	032-31-GL	50.00	mL/min	14.70 psia
014-16-ST	12.00	L/min	14.70 psia	092-05-GL	2.00	L/min	14.70 psia
064-13-GL	20.00	L/min	14.70 psia	102-21-ST	7.00	L/min	14.70 psia
				034-24-ST	14.00	L/min	14.70 psia
				044-25-CA	50.00	L/min	14.70 psia
				044-24-TA	66.00	L/min	14.70 psia
				044-06-ST	1.60	scfm	14.70 psia

TABLE 21 - DIRECT READING FLOW TUBES FOR OXYGEN							
65mm				150mm			
FLOW TUBE	QMAX	[UNITS]	PRESSURE	FLOW TUBE	QMAX	[UNITS]	PRESSURE
042-21-ST	10.00	mL/min	14.70 psia	032-33-ST	150.00	mL/min	14.70 psia
032-09-GL	35.00	mL/min	14.70 psia	062-02-ST	250.00	mL/min	14.70 psia
032-19-GL	50.00	mL/min	14.70 psia	112-04-SA	400.00	mL/min	14.70 psia
022-07-ST	300.00	mL/min	14.70 psia	062-16-CA	600.00	mL/min	14.70 psia
012-02-ST	500.00	mL/min	14.70 psia	082-08-SA	1.00	L/min	14.70 psia
052-02-GL	1.00	L/min	14.70 psia	102-12-SA	5.00	L/min	14.70 psia
013-25-ST	4.00	L/min	14.70 psia	102-17-CA	10.00	L/min	14.70 psia
034-08-ST	8.00	L/min	14.70 psia	034-15-ST	16.50	L/min	14.70 psia
044-04-ST	15.00	L/min	14.70 psia	044-19-CA	58.00	L/min	14.70 psia

TABLE 22 - DIRECT READING FLOW TUBES FOR PROPANE			
150mm			
FLOW TUBE	QMAX	[UNITS]	PRESSURE
092-01-ST	4.20	L/min	14.70 psia
102-02-CA	10.00	L/min	14.70 psia
044-02-ST	38.00	L/min	14.70 psia

COMMON EQUIVALENTS AND CONVERSIONS

Approximate Common Equivalents	
1 inch	= 25 millimeter
1 foot	= 0.3 meter
1 yard	= 0.9 meter
1 mile	= 1.6 kilometers
1 square inch	= 6.5 sq centimeters
1 square foot	= 0.09 square meter
1 square yard	= 0.8 square meter
1 acre	= 0.4 hectare +
1 cubic inch	= 16 cu centimeters
1 cubic foot	= 0.03 cubic meter
1 cubic yard	= 0.8 cubic meter
1 quart (lq)	= 1 liter +
1 gallon	= 0.004 cubic meter
1 ounce (avdp)	= 28 grams
1 pound (avdp)	= 0.45 kilogram
1 horsepower	= 0.75 kilowatt
1 millimeter	= 0.04 inch
1 meter	= 3.3 feet
1 meter	= 1.1 yards
1 kilometer	= 0.6 mile
1 square centimeter	= 0.16 square inch
1 square meter	= 11 square feet
1 square meter	= 1.2 square yards
1 hectare +	= 2.5 acres
1 cubic centimeter	= 0.06 cubic feet
1 cubic meter	= 35 cubic feet
1 cubic meter	= 1.3 cubic yards
1 liter +	= 1 quart
1 cubic meter	= 250 gallons
1 gram	= 0.035 ounces (avdp)
1 kilogram	= 2.2 pounds (avdp)
1 kilowatt	= 1.3 horsepower

Conversions Accurate to Parts Per Million	
inches X 25.4 <sup>+</sup>	= millimeters
feet X 0.3048 <sup>+</sup>	= meters
yards X 0.9144 <sup>+</sup>	= meters
miles X 1,609.34	= kilometers
square inches X 6.4516 <sup>+</sup>	= square centimeters
square feet X 0.92 903 0	= square meters
square yards X 0.836 127	= square meters
acres X 0.404 686	= hectares
cubic inches X 16.3871	= cubic centimeters
cubic feet X 0.028 316 8	= cubic meters
cubic yards X 0.764 556	= cubic meters
quarts (lq) X 0.946 353	= liters
gallons X 0.003 785 41	= cubic meters
ounces (avdp) X 28.3495	= grams
pounds (avdp) X 0.453 592	= kilograms
horsepower X 0.745 700	= kilowatts
millimeters X 0.039 370 1	= inches
meters X 3.280 84	= feet
meters X 1.093 61	= yards
kilometers X 0.621 371	= miles
sq centimeters X 0.155 000	= square inches
square meters X 10.7639	= square feet
square meters X 1.196 99	= square yards
hectares X 2.471 05	= acres
cu centimeters X 0.061 623 7	= cubic inches
cubic meters X 35.3147	= cubic feet
cubic meters X 1.307 95	= cubic yards
liters X 1.056 69	= quarts (lq)
cubic meters X 264.172	= gallons
grams 0.035 274 0	= ounces (avdp)
kilograms X 2.204 62	= pounds (avdp)
kilowatts 1.341 02	= horsepower

THESE PREFIXES MAY BE APPLIED TO ALL SI UNITS	
Multiples and Submultiples	
1 000 000 000 000	= 10 <sup>12</sup>
1 000 000 000	= 10 <sup>9</sup>
1 000 000	= 10 <sup>6</sup>
1000	= 10 <sup>3</sup>
100	= 10 <sup>2</sup>
10	= 10 <sup>1</sup>
0.1	= 10 <sup>-1</sup>
0.01	= 10 <sup>-2</sup>
0.001	= 10 <sup>-3</sup>
0.000 001	= 10 <sup>-6</sup>
0.000 000 001	= 10 <sup>-9</sup>
0.000 000 000 001	= 10 <sup>-12</sup>
0.000 000 000 000 001	= 10 <sup>-15</sup>
0.000 000 000 000 000 001	= 10 <sup>-18</sup>

Prefixes	Symbols
tara (ter'a)	T
giga (ji'ga)	G
mega (meg'a)	Ma
kilo (kil'o)	k*
hecto (hek'to)	h
deka (dek'a)	da
deci (des'i)	d
centi (sen'ti)	c*
milli (mil'i)	m*
micro (mil' kro)	u*
nano (nan'o)	n
pico (pe'ko)	p
femto (ferni'to)	f
atto (at'to)	a

+ common term not used in SI  
 \* exact  
 Source: NBS Special Pub. 304

## EUROPEAN SERVICE CENTER

Authorized service and Calibration Facility For Aalborg Products located in Germany \*SGS ISO9001 Certification is not applicable.  
ANALYT-MTC MESSTECHNIK GMBH - Klosterrunsstraße 18 P.O. Box 1321 Müllheim D-79379 Germany  
TELEFON: +49 (07) 631.5545 ● FAX: +49 (07) 631.14740 ● INTERNET: www.analyt-mtc.de ● E-MAIL: info@analyt\_mtc.de

\*Keine Zertifizierung nach SGS ISO9001.

## PRODUCTS MANUFACTURED BY AALBORG®

### ROTAMETERS

#### Single Tube

Aluminum / Brass / Stainless ● Interchangeable Glass Flow Tubes ● Optional Valves

#### Multiple Tube

Two to Six Channels ● Aluminum/ Stainless

#### PTFE Single and Multiple Tube

Chemically Inert ● 1 to 4 Channels ● Interchangeable Glass Flow tubes

#### Gas Proportioners

Aluminum / Stainless ● Used for Blending Two or Three Gases

#### Kits

Aluminum / Stainless / PTFE ● Including Five Glass Flow Tubes and a Set of Floats

#### PTFE - PFA

Chemically Inert ● Low to Medium Flow of Corrosive Liquids with PFA Flow Tube

#### Medium Range

Glass Safety Shield ● Dual Air and Water Scale

#### Optical Sensor Switch

Non-Invasive Means for Detection of a High or Low Flow

#### High Flow Industrial Stainless Steel Flow Meters

Heavy Duty Stainless Steel ● Direct Reading Air and Water Scales

### VALVES

#### Barstock

Brass / Stainless ● Standard or High Precision

#### PTFE

Chemically Inert ● Needle or Metering

#### Proportionating Solenoid

Stainless ● For Controlling Gas or Liquid Flow ● Pulse width Modulated

#### SMV ● Stepping Motor Valve

### PUMPS

#### Tubing Pumps Fixed RPM

#### Tubing Pump Heads

#### Tubing Pumps Variable Speeds

#### Dispensing Pumps

#### Flexible Tubings

### ELECTRONIC METERS and CONTROLLERS

#### Low Cost Mass Flow Meters

Aluminum / Stainless ● With or Without LCD Readout

#### Low Cost Mass Flow Controllers

Aluminum / Stainless ● With or Without LCD Readout

#### Mass Flow Controllers

Stainless ● One to Four Channel Systems

#### Totalizer

Accumulation Up to 7 Digits

#### Digital Mass Flow Controller

Auto Zero ● Totalizer ● Alarms ● Built in RS485

#### Multi Parameter Digital Mass Flow Meter

Displays flow Pressure and Temperature

#### Vortex In-Line and Insertion Flow Meters

Steam / Liquid and Gas Service

#### Input / Output Devices

RS232 / RS485 - Converts Analog to Digital and Digital to Analog