

OIL QUALITY SENSOR (OQSx)

Product Ref: OQSx-I-AA-02-5



➔ PRODUCT OVERVIEW

The Tan Delta OQSx oil condition monitoring sensor delivers the pinnacle in accuracy, performance and reliability for equipment operators who demand optimal reliability and productivity from their equipment. Proven around the world with leading equipment OEM's and operators, the OQSx sensor is configurable to any oil type in any application, hydraulics, engine, gear box, transformers, in real time – the OQSx will continuously monitor, detect and report any quality change.

➔ KEY PRODUCT FEATURES

- Full Spectrum Holistic Detection**
 Detects and measures all oil condition changes, no matter the cause – wear or contamination.
- Sensitive**
 Even the smallest change is detected enabling early detection of issues before equipment damage.
- Accurate**
 Absolute quality change detection and measurement accuracy and consistency.
- Robust and Reliable**
 Quality engineered from stainless steel. Suitable for deployment on any equipment in any environment.
- Real Time**
 Continuous inline monitoring in real time with instant detection and reporting
- Easy to Install**
 Simple to configure and install. Long term maintenance free continuous operation.

➔ BENEFITS

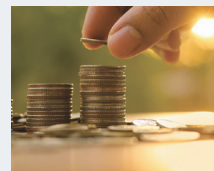

Lower Operating Costs
 Less downtime and less maintenance significantly reduces ongoing operating costs.



Optimise Service Intervals
 Optimise service intervals without risking equipment performance and reliability.



Improved Safety
 Ensures your equipment is in optimal condition making a safer working environment.



Help the Environment
 Increase equipment efficiency. Reduce oil consumption, maintenance activity and costs and conserve the environment.

OIL QUALITY SENSOR (OQSx)



➤ SPECIFICATIONS

Order Information

Product Name: Oil Quality Sensor (OQSx)
 Product Code: OQSx-I-AA-02-5

Physical

Material: Stainless Steel AISI304
 Dimensions: 90mm x 37mm (L x W)
 Weight: 160g
 Thread: 1/2" BSPP Thread / M32 Hex thread
 Seal: DIN 3869 Viton Seal
(Alternative seals and threads available upon request)

Connections

6 Pin Lumberg Male (IEC 61076-2-106)
(Alternative connections are available upon request)

Electrical

Power Supply: 9-30V DC
 Power Consumption: Average 0.4w continuous 30mA

Data Output/Input

Analogue Output: 2x4-20mA (current syncing, passive input)
 Digital Output: 1xRS485: 9600 baud half duplex, Modbus protocol supported on RS485, CANbus: CANopen protocol supported on RS485

Oil Quality Detection Parameters

Frequency: 15 per second
 Sensitivity: Certified better than 15ppm sensitivity
 Accuracy: +/-1%
 Elements: All wear and contamination elements

Oil Type

Configuration: Any synthetic or mineral oil - including fuel oils such as diesel and bio-diesel

Environmental

Sensor Temperature: -20°C (-4°F) to +120°C (+248°F)
 Fluid Temperature: -20°C (-4°F) to +120°C (+248°F)
 External Pressure: 0 bar (0 psi) to 20 bar (290 psi)
 Fluid Pressure: up to 20 bar (290 psi)

Standards and Certification

Water & Dust: IP67 when connected
 Shock & Vibration: BS EN 60068-2-30 (Test Db - Cyclic Humidity)
 BS EN 60068-2-6 (Test Fc - Sine Vibration)
 BS EN 60068-2-27 (Test Ea - Mechanical Shock)

EMC:

EN 61000-6-4:2007 (Generic Emissions Standard for Industrial Environments)
 EN 61000-6-2:2005 (Generic Immunity Standard for Industrial Environments)

➤ WHATS IN THE BOX

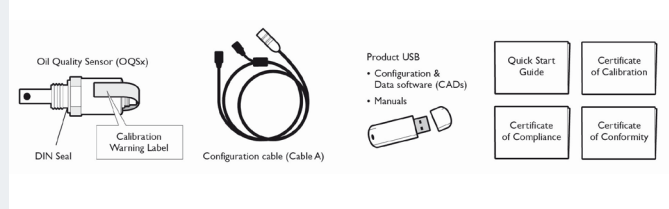

➤ DIMENSIONS

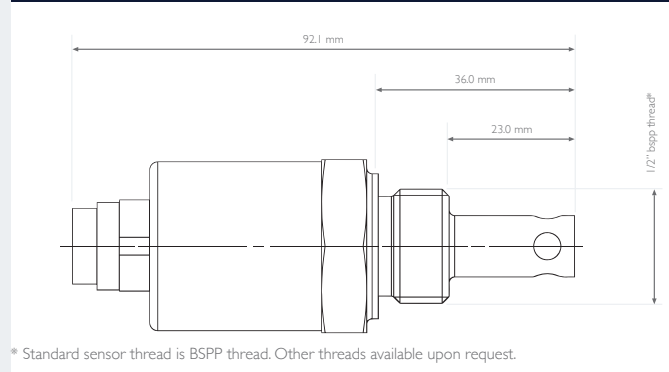

➤ ABOUT TAN DELTA

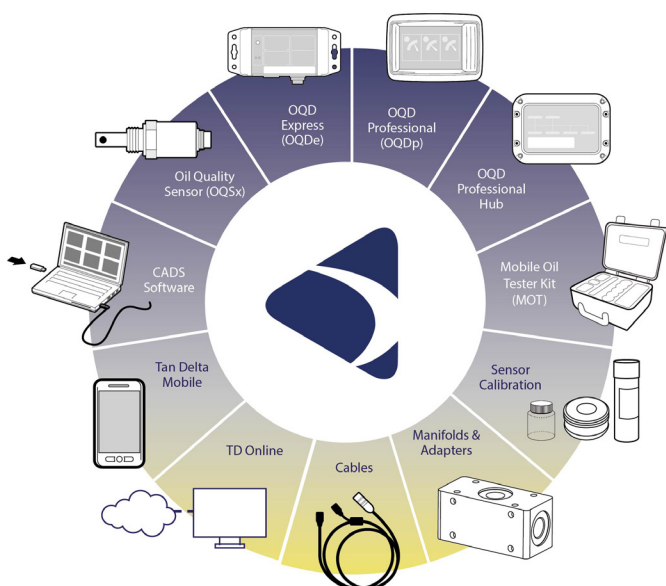

Tan Delta Systems Limited is a global leader in the development and supply of advanced oil condition monitoring technologies, with a fully integrated product portfolio all engineered and developed from the initial core product, the oil quality sensor (OQSx).

Our products are trusted by the world's leading industrial and commercial companies to monitor oil condition, helping to optimise equipment productivity, reduce operating costs, thereby remaining competitive in a global economy.

All Tan Delta products are engineered and quality manufactured for long term continuous operation in the harshest commercial and industrial environments. Each product is carefully engineered and tested to withstand the long term effects of extreme shock, vibration, heat, cold, thermal shock, electrical interference and many more factors.

The Tan Delta Customer Support team partners with customers to implement highly effective and commercial beneficial oil conditioning. Our experience and expertise enable customers to quickly and smoothly implement successful condition monitoring.

Tan Delta provide ongoing 24/7 global warranty support, technical support, advice and consultancy to ensure customers maximise the long term benefits of their investment in oil condition monitoring.

Tan Delta Systems Limited is always looking to exceed customer expectations, so for this reason reserves the right to alter, without notice, the specification, design or conditions of supply of any product or service. Information provided by Tan Delta Systems is believed to be accurate and reliable. However, no responsibility is assumed by Tan Delta Systems for its use, nor any infringements of patents or other rights of third parties, which may result from its use. No license is granted by implication or otherwise under any patent or patent rights of Tan Delta Systems ©Tan Delta Systems Ltd 2017

