

BONETTI®



BONT®

**Magnetic
Level Gauges**

**Remote Reading
Systems**

**Magnetic
Level Switches**

INDEX	Page	Page
Operating Principle	3	Magnetic Level Gauges
Design.....	3	- of Stainless Steel
Applications	3	for PN 10/40 - 400.....
Materials	3	6-7
Operating Conditions	3	- of Synthetic Polymers
Types and Classes	3	8
Material Schedules	4	- of Stainless Steel
C to C Distance.....	4	PTFE lined
Visible Length	4	9
Connections.....	4	- Series for Water / Steam
Accessories	4-5	up to 210 bar pressure
Startup and Stop.....	5	10-11
Servicing.....	5	- type MAG-RDR for Remote Direct Reading.....
Enquiries and Purchase Orders.....	5	12
		- with Float immerse in the Vessel (Top Mounting).....
		13
		Remote Transmission System Type MST
		14
		- Sensing Elements
		15
		- Indicator / Trasmitter type MST-X
		16
		Remote Transmission System Type MLS
		17
		Magnetic Level Switches
		- type MAG-LIS.....
		18

FIGURE NUMBER INDEX

Fig.	Page	Fig.	Page	Fig.	Page	Fig.	Page.
3303	4	3324.1	8	3332	12	3342	3
3304	4	3324.2	8	3333	13	3343	7-10
3305	5	3325	9	3334.1	15	3344	15
3306	5	3326	7	3334.2	15	3345	11
3308	5	3327	10	3335	15	3346.1	5
3321	6	3330	18	3336.1	16	3348	17
3322	6	3331	9	3337.1	16	3349	17

BONT® Magnetic level gauges are designed and manufactured in compliance with the international standards ISO 9001, "PED" - 97/23/EC Pressure Equipment Directive and "ATEX" 94/9/EC. These instruments have been also approved by several bodies, organizations and national and international authorities. For further information, please apply to our commercial department

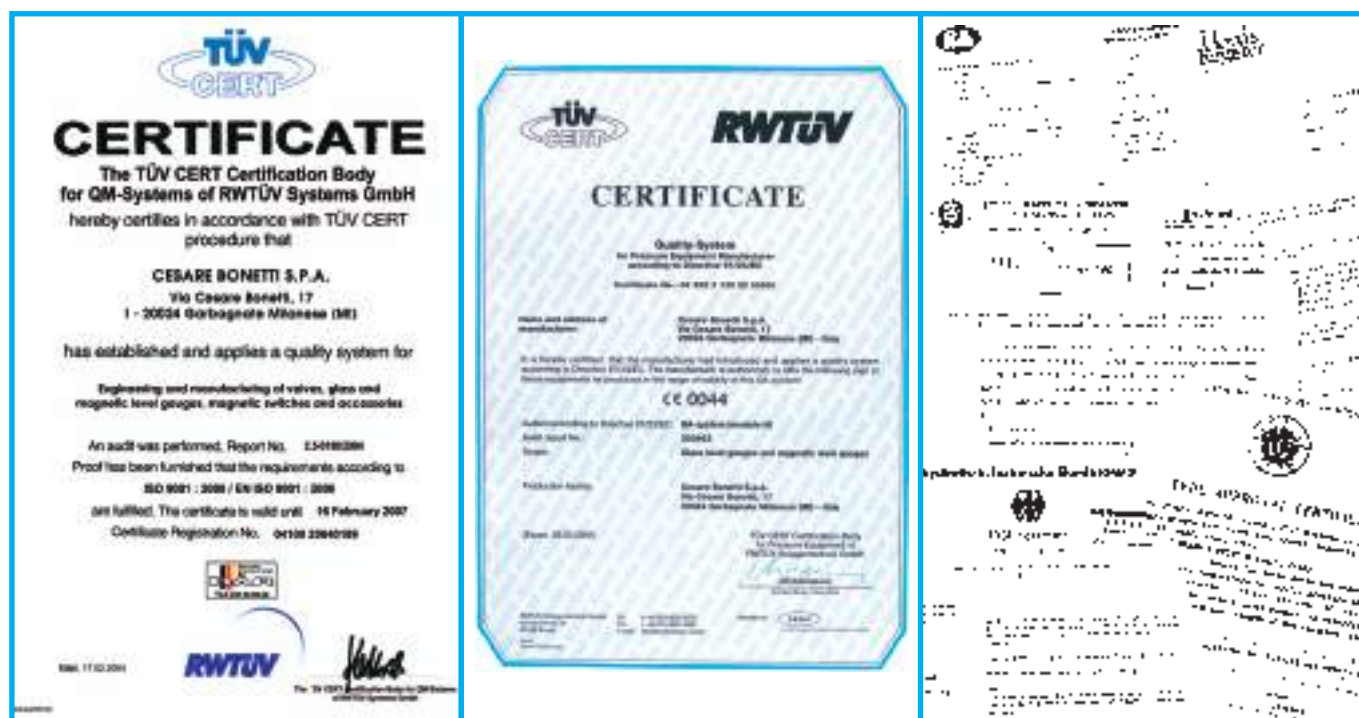

BONT® Magnetic level gauges

OPERATING PRINCIPLE

The operation of the BONT® magnetic level gauge is based on some elementary physical principles:

- The principle whereby the liquid in communicating vessels is always at the same level,
- Archimede's principle according to which a body immersed in a liquid receives a buoyancy equal to the weight of displaced liquid,
- The principle of attraction between North and South poles of two permanent magnets and that of repulsion between like poles.

This principle has two applications in the BONT magnetic level gauge:

- first between the magnet in the chamber float and every single magnet of the indicating scale,
- second between the magnets of the indicating scale.

DESIGN

The BONT® magnetic level gauge consists of:

- a vertical chamber consisting of a tube of suitable diameter and thickness containing a float wherein a permanent magnet is placed exactly on the liquid level line;
- two horizontal stub pipes for connection to the vessel containing the liquid of which we wish to know the level;
- two stop valves (recommended, but not mandatory) one on each stub pipe, to isolate the level gauge ;
- an indicating scale, outside the vertical chamber, consisting of a case of non-magnetic material with transparent front face containing a set of small permanent magnets enclosed in small cylinders which can rotate on their horizontal axis.

These cylinders show an external surface having two different colours.

According to the orientation of each magnet (due to the action of the magnet in the float) each cylinder will show externally half of its surface of one colour or the other.

The indicating scale will be of one colour (e.g. white) over the chamber area taken up by gas, vapour or steam phase contrasting with the other colour (e.g. red) over the chamber area taken up by liquid phase.

Alarm system for damaged float. The three bottom cylinders of the indicating scale are placed lower than the bottom connection of the magnetic level gauge. They are used for control of float efficiency. With float damaged and its consequent sinking in the liquid, these three cylinders show the yellow surfaces.

These level gauges are very suitable for interface reading: the level gauge float has only to sink in the liquid having lower specific gravity and to float on the liquid having higher specific gravity.

In spite of its simple operating principle, the BONT® magnetic level gauge represents the result of long research and experience in design, sizing, choice of materials and manufacturing technology, which brought to the production of one of the most reliable measure instruments

APPLICATIONS

The application range is very wide and includes all the situations where the fluids are:

- at high pressure, at low or high temperature,
- at low pressure, at low or high temperature,
- chemically aggressive,
- pollutant to environment,
- noxious or poisonous for people health,
- inflammable or explosive,
- with identical optical characteristics of the superimposed phases (interface)

MATERIALS

The most utilised materials are:

Vertical Chamber: Tp 316 - Tp 316L - Tp 321

PVC - PP - PVDF - PTFE

Float: Tp 316 - Titanium - PVC - PP - PVDF - PTFE

Indicating Scale: Austenitic stainless steel / glass,

Water proof - IP 65AS per IEC 529.

According to the operating conditions, we supply level gauge with the most suitable combination of materials. Iron, copper and silver alloys are normally excluded.

Special materials, like Hastelloy, Incoloy, Titanium, Zirconium, 6Mo, etc. will be supplied on request.

OPERATING CONDITIONS

The BONT® Magnetic Level Gauges are manufactured in different Types and Classes, for various operating conditions, listed below in Fig. 3342.

Plant operating and design conditions must be clearly indicated to choose a suitable level gauge

The selection of the level gauge depends also on the specific gravity of the vessel liquid (see page 7 and following)

If you want to use a level gauge for conditions different (less severe too) from those to which it was originally supplied, please contact our Engineering Department.

Fig. 3342

Type - Class	MAX operating temperature (°C)	-10	+20	38	50	100	120	150	200	250	300	350	375	400
MAG / MNP – Class	MAX Operating Pressure (bar)	9	9	9	9	9	9	9	9	9	9	9	7	7
		A1	A1	A1	A1	A1	A1	A1	A1	A1	A1	A1	A1	A1
MAG / MLP – Class	MAX Operating Pressure (bar)	27	27	26	20	18	16	13	11	10	10	7	7	
		A2	A2	A2	A3	A3	A3	A4	A4	A4	A4	A5	A5	
MAG / TLP – Class	MAX Operating Pressure (bar)	60	60	60	50	45	39	22	17	12	10	10	9	
		B1	B1	B1	B3	B4	B5	B6	B6	B7	B8	B9	B10	
MAG / TLPS – Class	MAX Operating Pressure (bar)				60	60	58	58	52	48	42	39	27	
					C1	C1	C2	C2	C3	C4	C5	C6	C7	
MAG / THP – Class	MAX Operating Pressure (bar)	118	118	118	85	71	66	38	33	29	18	15	13	
		F1	F1	F2	F3	F4	F5	F6	F7	F8	F9	F10	F11	
MAG / THPS – Class	MAX Operating Pressure (bar)				118	115	115	98	88	80	67	65	63	
					G1	G1	G1	G2	G3	G4	G5	G6	G7	
MAG / THPX – Class	MAX Operating Pressure (bar)	170	170	170	170	168	167	165	160	155	149	146	144	
		H1	H1	H1	H1	H1	H1	H1	H1	H1	H1	H1	H1	
MAG210 / THP – Class	MAX Operating Pressure (bar)	291	291	291	265	255	240	220	205	195	190	185	180	
		N1	N1	N1	N1	N1	N1	N1	N1	N1	N1	N1	N1	
MAG210 / THPS – Class	MAX Operating Pressure (bar)	388	388	388	388	385	385	385	370	350	335	330	325	
		P1	P1	P1	P1	P1	P1	P1	P1	P1	P1	P1	P1	

MATERIAL SCHEDULES

With this expression we intend to define by means of a tag the types of materials used for the main components that constitute a BONT® magnetic level gauge
The most used Material Schedules are listed below.

Material Schedule	Vertical Chamber and Stub Ends	Float	Remaining Wetted Parts	NOT Wetted Parts
36/52	Tp 316L	Tp 316	A 105	A 105
36/63	Tp 316L	Tp 316	Tp 316	inox
36/64	Tp 316L	Tp 316	Tp 316	A 105
TIT/52	Tp 316L	Titanium	A 105	A 105
TIT/63	Tp 316L	Titanium	Tp 316	inox
TIT/64	Tp 316L	Titanium	Tp 316	A 105
PVC	PVC	PVC	PVC	PVC
PP	PP	PP	PP	PP
PVDF	PVDF	PVDF	PVDF	PVDF
PTFE	Tp 316 + PTFE	PTFE	PTFE	A 105

Slip-on flanges are manufactured in the most suitable material.

Flange connecting bolts are of the most suitable material.

CENTRE TO CENTRE DISTANCE VISIBLE LENGTH

Our magnetic level gauges are manufactured with the C to C and Visible Length requested by customers, up to approx 6,500 mm for level gauges having a stainless steel vertical chamber and up to approx 3,500 mm for level gauges having a vertical chamber in synthetic polymers.

Longer C to C distances are manufactured with an intermediate flanged connection.

Normally the visible length is equal to the Centre to Centre distance of the tank connections.

CONNECTIONS

We always recommend the fitting of shut-off cocks/valves between level gauge and vessel.

Connections arrangement

The standard and most requested arrangement (see Fig. 3303 - arrang. 1) consists of 2 horizontal vessel connecting stub ends fitted on same vertical.

Different arrangements (see arrang. 2, 3, etc.) can be made for special requirements.

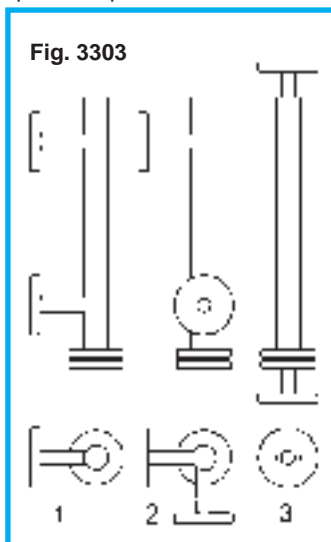

Connections types.

The connections between the gauge body and the vessel (both with or without shut-off cocks or valves) are supplied according to Customer request.

The most common end connections are:

- welded flanges;
- slip-on flanges;
- male threaded;
- female threaded;
- threaded union nut for 3-piece connection;
- S.W.;
- B.W..

PN, DN and facing Standards to be indicated by Customer.

INDICATING SCALE

Each instrument is equipped with an indicating scale, fixed to the gauge chamber, fixed to the gauge chamber by means of brackets with spring or hose clamps.

The scale is made of rotating cylinders housed in a one piece case of austenitic stainless steel with glass in the front to allow the reading.

The scale allows continuous reading. The length of the scale is suitably sized for the gauge;

Axis to axis distance between cylinders is 10 mm.

The last bottom five cylinders of the indicating scale, positioned below the bottom nozzle connection to the vessel, provide visual alarm indication in case of float failure

Different versions of the indicating scale are available:

- Standard Scale

The standard scale is water proof. The sealing is obtained using silicone gaskets.

The cylinders are of plastic material of white/red colour, suitable for fluid operating temperature up to 200 °C.

- High Temperature Scale

In this scale the cylinders are of special plastic material of white/black colour, suitable for fluid operating temperature up to 400 °C. These white/black cylinders may be used also in standard scales for better reading in case of black/white television remote transmission. In case of higher temperatures special indicating scales are available.

- Scale with Non-frosting Extension

Perspex non-frosting block extension with a protrusion sized depending on the process fluid operating temperature is fitted and sealed on the standard indicating scale.

This solution allows the reading of the level also in case of frost on the gauge chamber and scale.

ACCESSORIES

Shut-off, drain and vent valves and cocks

We produce and can supply a wide and complete range of shut-off, drain and vent valves and cocks, specifically designed for level gauge application, as described in following pages.

Calibrated Scale.

At the side of the indicating scale a stainless steel calibrated scale can be assembled (see Fig. 3304).

The standard calibration is in cm.

On request any different calibration or material can be supplied.

Fig. 3304



Magnetic Switches.

It is advisable, but not indispensable, that the fixing of the magnetic switches to the level gauge is made by the gauge manufacturer. Please state in your order if there are specific reading ranges within which the switch setting has to be made, or if the setting is to be considered continuous on all the length of the indicating scale. In both cases as the switch is fitted to the gauge chamber with a stainless steel amagnetic bracket, the position can be easily and precisely set without any special tool. The switches can be added also subsequently to delivery of the gauge.

Any switch can be located:

- with respect to the height of the gauge scale:
 - adjustable with continuity at the required level on the whole length of the indicating scale
 - adjustable within specific range to be stated in the order.
- with respect to the horizontal plane (Fig. 3305):
 - located at 180° in respect to the indicating scale, with an allowance range particularly wide, that is of ±55°
 - at the side of the indicating scale, indifferently on the left or right side, and on both sides.

Therefore there is the possibility of having more than one magnetic switch at the same level (Fig. 3305), provided that it is not placed into the two blind areas indicated with A in Fig. 3305.

Please state in your order whether there are specific needs in the location of switches.

Fig. 3305

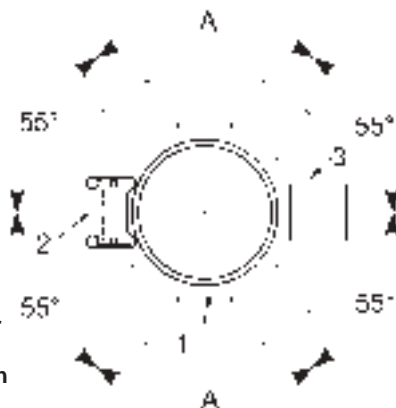

- 1 - Gauge chamber
- 2 - Indicating scale
- 3 - Magnetic Switch position
- A - Blind area

Each magnetic switch contains one or more electric contacts for opening/closing the control circuits for: Low Level alarm, High Level alarm, pump starting, pump stopping, warning, etc. The most used switches are suitable for 0.28 A at 230 V, 60 VA; max current of contact: 1 A at 60 V. A suitable relay should be fitted for higher power supplies.

We supply different types of magnetic switches:

- monostable, bistable
- explosion proof, etc.

Choice of magnetic switches should be made according to planned wiring diagram and safety standards of plant.

Remote Reading.

For remote transmission of the reading of the magnetic level gauge systems type MST (Page 14 and following) and type MLS (page 17) are available

Heating / Cooling.

Level gauge, depending on contained fluids, can be heated / cooled.

Level gauge for these applications is equipped with heating equipment which can consist of:

- one externally fitted pipe contacting vertical chamber and traced by steam, heat transfer fluid, etc. (Fig. 3306);
- a heating cable externally in contact with the chamber (Fig. 3346). On request it can be equipped with a thermostat;
- one stainless steel jacket welded externally on vertical chamber; space between jacket and vertical chamber is traced by heating fluid (Fig. 3308). Section of space is very wide with respect to section of vertical chamber, therefore heating action is very effective.

Heating of shut-off valves could be considered.

Insulating of the instrument can be performed on site, after installation, if necessary.

Do not insulate indicating scale or other accessories.

Fig. 3306



Fig. 3346.1

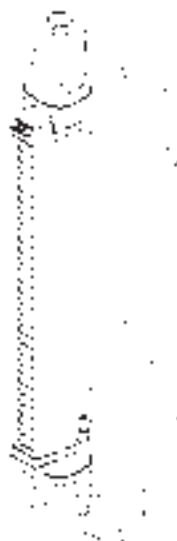

Fig. 3308



START UP AND STOP

Some level gauge types as well as special operating conditions need, during start-up and stop operations, a strict compliance with the instructions enclosed with each instrument.

SERVICING / MAINTENANCE

These instruments do not usually require any maintenance.

ENQUIRIES AND PURCHASE ORDERS

When placing orders or inquiries, please state:

- type of fluids contained in the level gauges and their specific gravity,
- plant operating and design pressure,
- plant operating and design temperature,
- centre to centre distance (CC),
- visible length,
- type and size of vessel connections.

This equipment is patented in Italy and in the main Countries.

BONT® Magnetic Level Gauges of Stainless Steel for PN 10/40 - 400

- 1 These Magnetic Level Gauges are manufactured in the Types and Classes listed in Fig. 3342, Page 3. Plant operating and design conditions must be clearly indicated for choice of suitable level gauge. Choice of level gauge depends also on specific gravity of the medium. If you want to use a level gauge for conditions different (less severe too) from those to which it was originally supplied, please contact our Engineering Department.

- 2 The most used Material Schedules are listed below.

Material Schedule	Vertical Chamber and Stub Ends	Float	Remaining Wetted Parts	NOT Wetted Parts
36/52	Tp 316L	Tp 316	A 105	A 105
36/63	Tp 316L	Tp 316	Tp 316	inox
36/64	Tp 316L	Tp 316	Tp 316	A 105
TIT/52	Tp 316L	Titanium	A 105	A 105
TIT/63	Tp 316L	Titanium	Tp 316	inox
TIT/64	Tp 316L	Titanium	Tp 316	A 105

Slip-on flanges are manufactured in the most suitable material.
Flange connecting bolts are of the most suitable material.

- 3 These level gauges are supplied:
- without shut-off valves (Fig. 3321),
 - with shut-off valves. Fig. 3322 shows a level gauge with Stellite seated BONT® valves. We also supply level gauges with sleeve-packed cocks (Fig. 3326), piston valves (Fig. 3343), bellows sealed valves, ball valves or different shut-off elements.

We recommend the fitting of shut-off devices between level gauge and vessel.

- 4 Vessel connections are usually flanged. Standard flanges are:
- DIN: DN 20 ÷ 25, PN 40 ÷ 100;
 - ASME: 3/4" ÷ 1", Class 300 ÷ 600.
- 5 Bottom end is usually equipped with a flange having a 1/2" NPT drain plug to ASME B1.20.1. Plug can be replaced by:
- a 1/2" NPT-F sleeve-packed cock;
 - a 1/2" NPT-F needle valve;
 - a Piston valve;
 - a Bellows Sealed valve;
 - a Ball Valve;
 - a BONT® valve with stellite seat and disk.
- In such cases the overall dimension "B" will increase.
- 6 Top end is usually supplied with a vent plug 1/2" NPT to ASME B1.20.1. As to possible vent cock or valve, see paragraph 5.

Fig. 3321

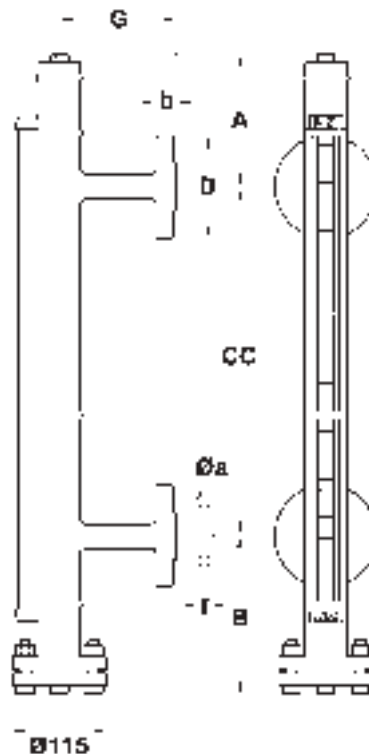
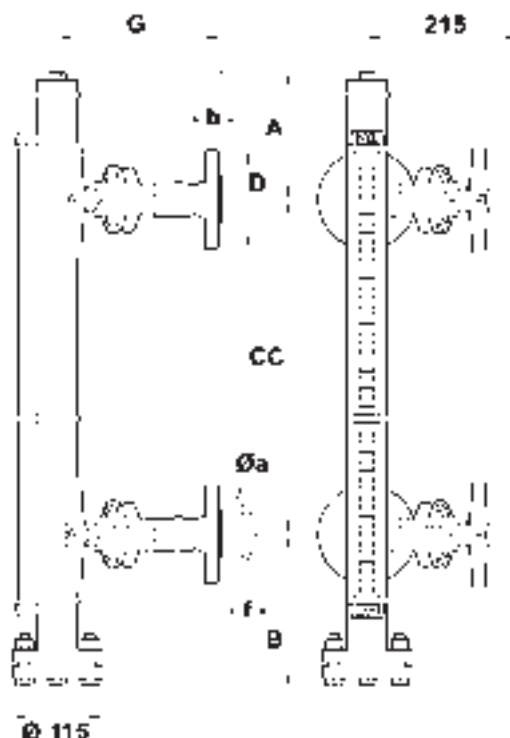

Fig. 3322



7 Overall dimensions of level gauge depend on operating conditions as well as on process fluid. Usually they can be obtained from tables below:

For vertical chamber obtained from pipe \varnothing 48,3 x 1,65 and float of Tp 316		
for specific gravity g / cm^3	A mm	B ★ mm
0,750 - 0,809	245	430
0,810 - 0,909	210	365
0,910 - 1,110	175	360

For vertical chamber obtained from pipe \varnothing 48,3 x 1,65 and float of Titanium		
for specific gravity g / cm^3	A mm	B ★ mm
0,415 - 0,444	235	520
0,445 - 0,484	235	455
0,485 - 0,525	235	400
0,526 - 0,580	235	374
0,581 - 0,663	200	320
0,664 - 0,870	165	274

For vertical chamber obtained from pipe \varnothing 60,3 x 3,91 and float of Titanium		
for specific gravity g / cm^3	A mm	B ★ mm
0,765 - 0,794	235	399
0,795 - 0,891	240	333
0,892 - 1,050	210	265

Adequately ballasted floats are used with liquids having specific gravity over 1,100 g/cm^3 .

★ A further free area, besides B dimension, is needed for fitting and/or removing float. Its dimension is approx 300 to 400 mm and depends on float length.

- 8 When ordering or requesting prices, please state:
- type of fluids contained in the level gauge and their specific gravity,
 - plant operating and design pressure,
 - plant operating and design temperature,
 - centre to centre distance (CC),
 - visible length,
 - type and size of vessel connections.

9 Magnetic level gauges suitable for liquids with specific gravity lower than those indicated in above tables are available. Please contact our Technical Department.

This Magnetic Level Gauge is patented in Italy as well as in other Countries.

Fig. 3326

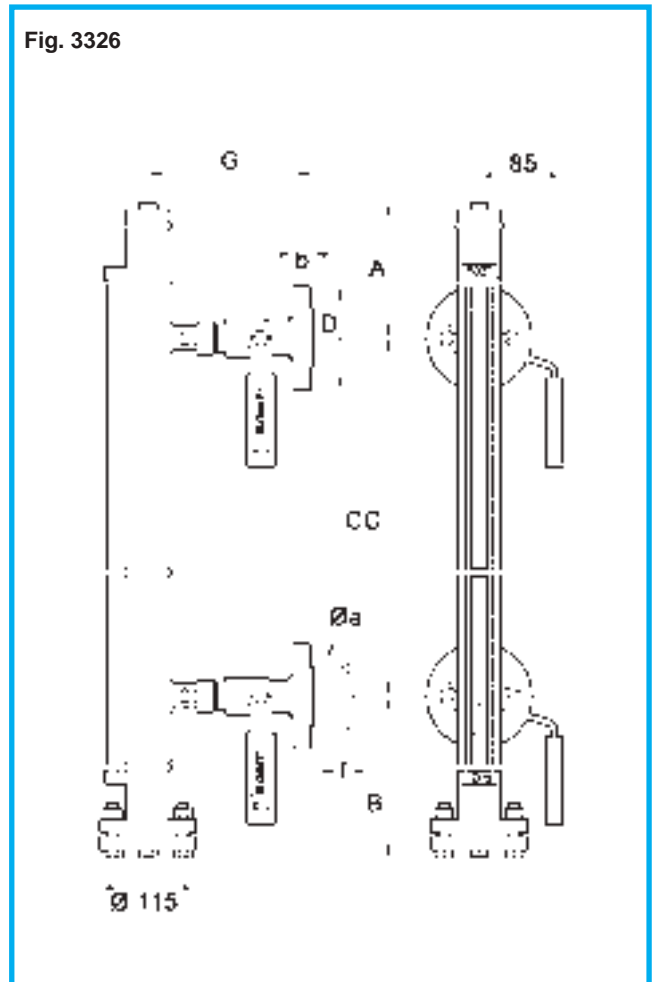
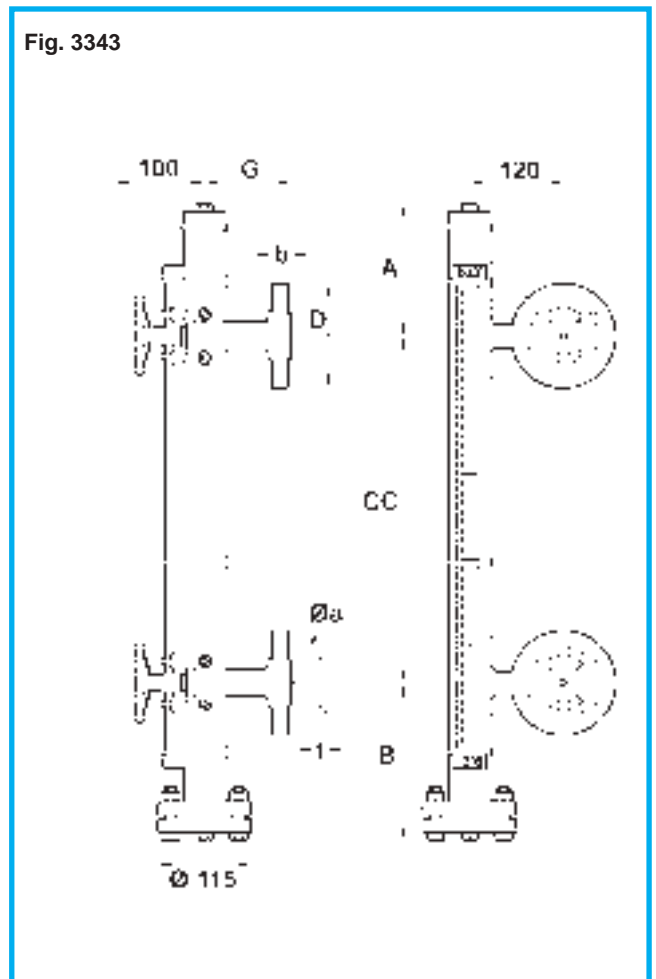

Fig. 3343



BONT® Magnetic Level Gauges of Synthetic Polymers

- 1 These level gauges are manufactured in type MAG-MNP only. Max operating conditions depend on used material. Usually they are as follows:

Material Schedule	Vertical chamber pipe Ø x thickness	Max Operating Conditions	
		Pressure bar	Temperature °C
PVC-U	Ø 50 x 3,9	0,5	60
PVC-C	Ø 50 x 3,9	0,5	100
PP	Ø 50 x 2,9	0,5	90
PVDF	Ø 50 x 3,0	0,5	-40 up to +140
Gauges for PN 10 available on request			

- 2 Material Schedules consist of following materials:

Material Sched.	Vertical Chamber and Stub Ends	Float *	Remainig Wetted Parts	NOT Wetted Parts	Fig.
PVC	PVC	PVC	PVC	PVC	3324.1
PP	PP	PP	PP	PP	3324.2
PVDF	PVDF	PVDF	PVDF	PVDF	3324.1

Slip-on flanges are manufactured in the most suitable material. Flange connecting bolts are of the most suitable material.

* The float can be supplied of noble or high alloy metal, provided it is compatible with the process fluid.

- 3 These level gauges are supplied:
- without shut-off valves (Fig. 3323),
 - with shut-off valves (Fig. 3324).
- Anyway we recommend fitting of shut-off valves.
- 4 Vessel connections are usually flanged. Standard flanges are: UNI PN 10 - DN 20 or DN 25 or DN 40; ASME B 16.5 - 150 RF 3/4" or 1" or 1.1/2".
- 5 Bottom end is usually equipped with a flange having a 1/2" BSP drain plug. Drain plug can be replaced by a valve DN 10. With this application, overall length increases of approx. 100 mm.
- 6 Top end is supplied with a vent plug 1/2" BSP. As to fitting of vent valve see paragraph 5.
- 7 Overall dimensions of level gauge depend on operating conditions as well as on process fluid. Generally they are as follows:
- Dimension A approx. 110 mm,
 - Dimension B approx. 170 mm.
- A further area, besides B dimension, is needed for fitting and/or removing float. Its dimension is approx. 200 mm and depends on float length.
- 8 When ordering or requesting prices, please state:
- type of fluids contained in the level gauge and their specific gravity,
 - plant operating and design pressure,
 - plant operating and design temperature,
 - centre to centre distance (CC),
 - visible length,
 - type and size of vessel connections.
- 9 These instruments are usually used with fluids having specific gravity ≥ 1 g/cm³.

This Magnetic Level Gauge is patented in Italy as well as in other Countries.

Fig. 3324.1



Fig. 3324.2

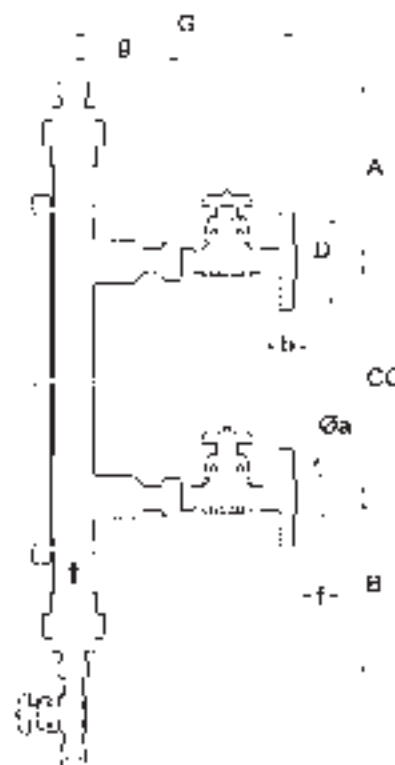

BONT® Magnetic Level Gauges of Stainless Steel, PTFE lined

- 1 These level gauges are manufactured in type MAG-MNP only. Max operating conditions depend on used material. Usually they are as follows:

Material Sched.	Vertical Chamber	Max Operating Conditions	
		Pressure bar	Temperature °C
PTFE	Tp 316 Ø 60.3 x 2.77 + PTFE: 3 mm min.	0,5	-25 up to +150
Gauges for PN 10 available on request			

- 2 Material Schedule PTFE consists of following materials:

Material Sched.	Vertical Chamber	Float *	Remaining Wetted Parts	Stub End and remaining NOT Wetted Parts
PTFE	Tp 316 + PTFE	PTFE	PTFE	A 105
Slip-on flanges are manufactured in the most suitable material. Flange connecting bolts are of the most suitable material. ★ The float can be supplied of noble or high alloy metal, provided it is compatible with the process fluid.				

- 3 These level gauges are supplied:
- without shut-off valves (Fig. 3347),
 - with shut-off valves, usually with flanges fitted on stub ends.
- Anyway we recommend fitting of shut-off valves.
- 4 Vessel connections are usually flanged. Standard flanges are: UNI PN 10 - DN 25; ASME B 16.5 - 150 RF - 1". Flanges are usually slip-on. Raised face has the dimensions as in Fig. 3331.
- 5 Bottom and top ends are equipped with a flange having a cap which can be replaced by a valve, on both bottom and top end.
- 6 Overall dimensions of level gauge depend on operating conditions as well as on process fluid. Generally they are as follows:
- Dimension A approx. 90 mm.
 - Dimension B approx. 90 mm.
- A further free area, besides B dimension, is needed for fitting and/or removing float. Its dimension is approx. 250 mm and depends on float length.
- 7 When ordering or requesting prices, please state:
- kind of fluids contained in the level gauge and their specific gravity,
 - plant operating and design pressure,
 - plant operating and design temperature,
 - centre to centre distance (CC),
 - visible length,
 - type and size of vessel connections.
- 8 These instruments are usually used with fluids having specific gravity $\geq 1 \text{ g/cm}^3$.

This Magnetic Level Gauge is patented in Italy as well as in other Countries.

Fig. 3325

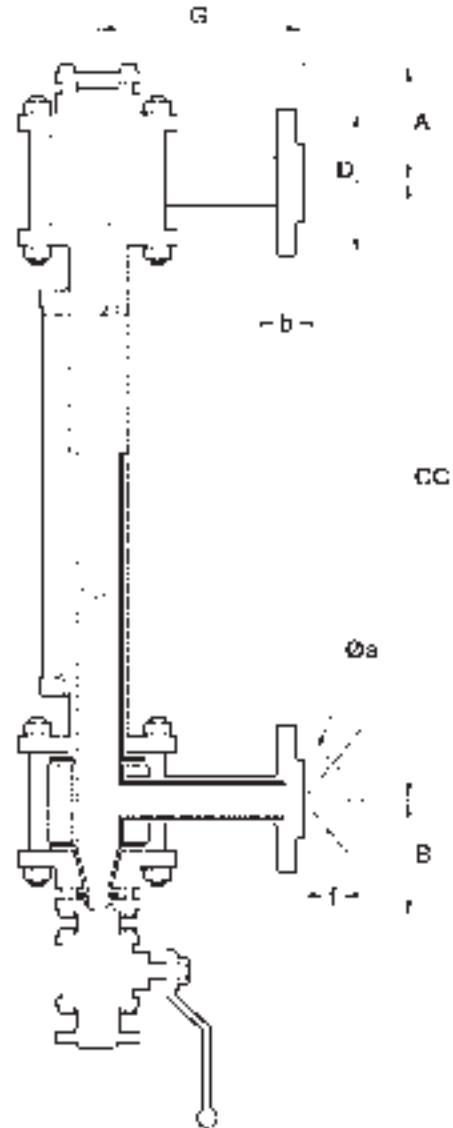
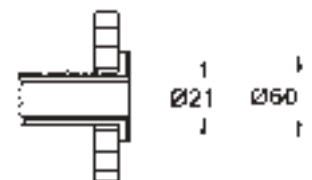

Fig. 3331



BONT® Magnetic Level Gauges For Water / Steam up to 210 bar Pressure

Type and Class	Figure	Material Schedule	Material		Fluid	MAX Operating Conditions		Overall Dimensions		
			Vert.	Float		Pressure bar	Temperature °C	A mm	B mm	E mm
MAG / MNP - MLP	3343	TIT/52	Tp 316L	Titanium	Saturated Water Steam	As indicated in Table Fig. 3342	210	365	—	
MAG / TLP - TLPS	3343	TIT/52	Tp 316L	Titanium			165	274	—	
MAG / THPS	3327	TIT/52	Tp 316L	Titanium			235	—	710	
MAG 210 / THP	3345	SPEC	Tp 321	Titanium			233	—	770	

Choice of materials can be modified according to the environmental conditions of plant (outdoor/indoor, cold/warm/tropical climate).

- These magnetic level gauges are for saturated steam applications and can be installed on a steam boiler drum for service under the conditions listed in table Fig. 3342 (see page 3). They can withstand all transient states: starting, warm standstill, cold standstill, quick depressurization of boiler drum where they are fitted.
- These level gauges are always supplied with 2 stop valves. If required by operating conditions, a drain valve - necessary for commissioning - is supplied.
- Vessel connections are usually flanged, size DN 20 (3/4") or DN 25 (1"), machined to the required Standards (DIN - ASME etc.) and to the PN (Rating Class) for the required application.
- Each level gauge is manufactured with the requested C to C distance, up to approx. 6,500 mm. The C to C distance corresponds usually with the visible length. The indicating scale is a continuous reading instrument, monoblock. It is fixed on the vertical chamber and can be orientated on plant site without special tools. One or more switches can be fitted on level gauge at the desired position, to operate alarms, start or stop of pumps, signalling etc. See also remote transmission systems type MST (Page 14 and following) and MLS (page 17).
- The bottom end is usually supplied with a flange enabling fitting of float and internal cleaning. Flange has a drain plug or a drain valve, depending on operating conditions.
- The top end is equipped with:
 - a welded end cap and a vent plug, or
 - a flange identical to the bottom one and a vent plug.
 On request we supply a vent valve for both applications.

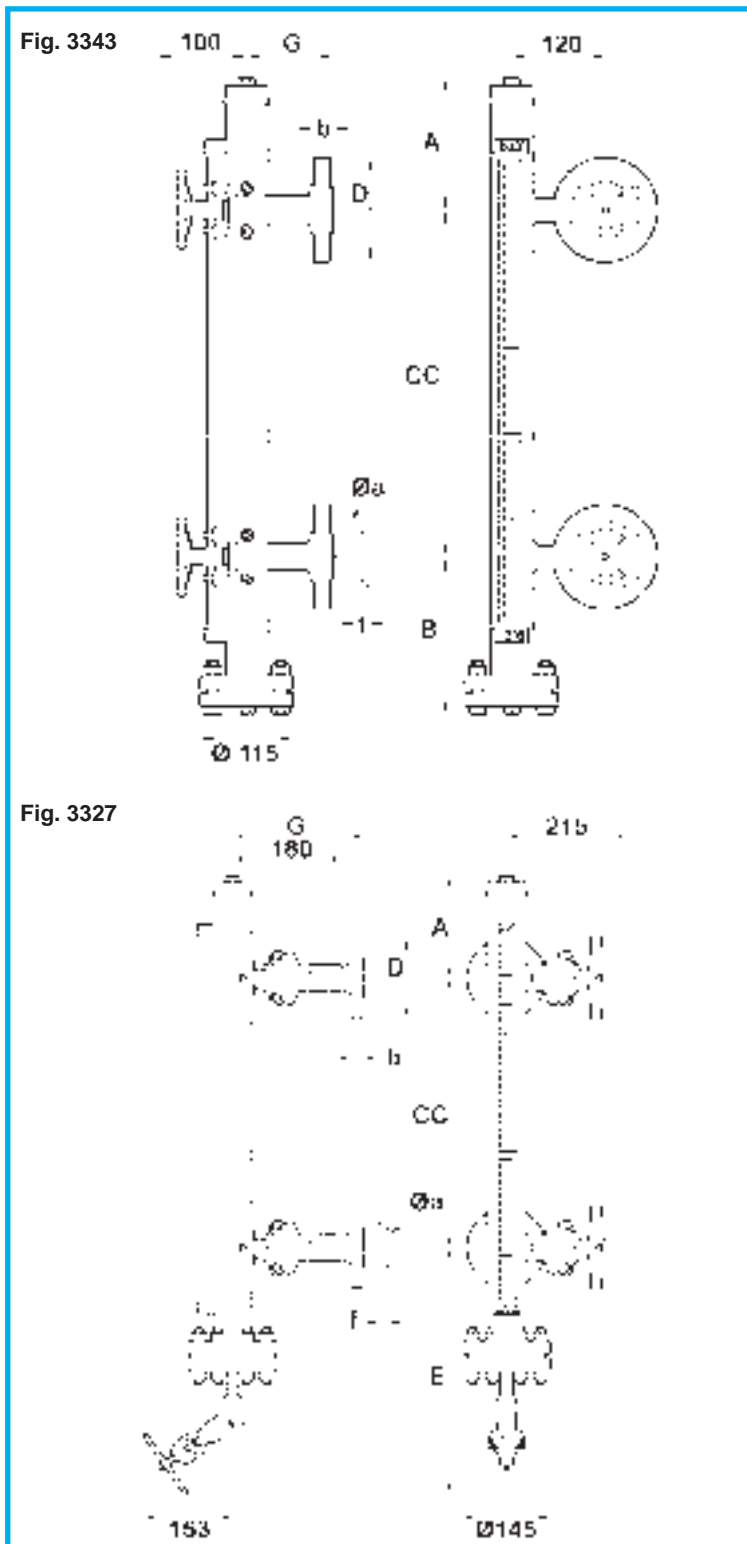

- 7 The overall dimensions of level gauge are those listed in the table and figures. Some of these depend on the size of the selected flanges.
- A further free area, besides B (or E) dimension, is needed for fitting and/or removing float. Its dimension is approx 300 to 400 mm and depends on float length.
- 8 When ordering or requesting, please state:
- type of fluid contained in the level gauge: water and saturated water steam at bar pressure.
 - possible temperature transient at°C
 - the C to C distance (CC)
 - the visible length
 - the type and size of vessel connections (DN, PN, finishing, Standards etc.)

These Magnetic Level Gauges are patented in Italy as well as in other Countries.

Fig. 3345

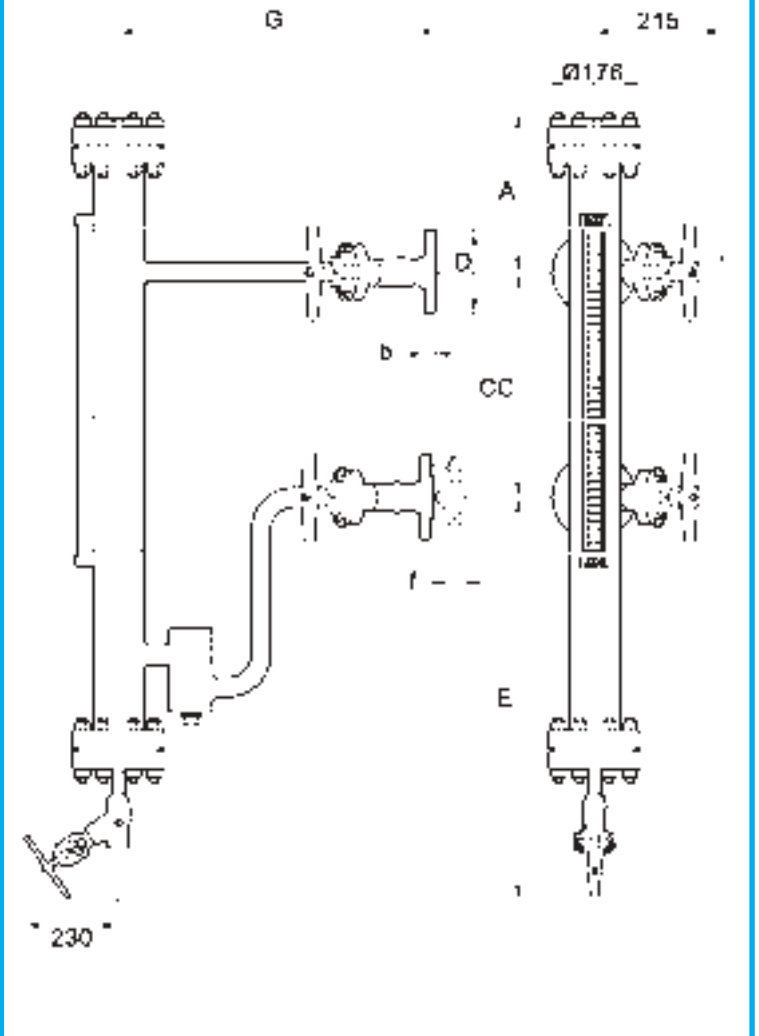

BONT® Magnetic Level Gauges for Remote Direct Reading - type MAG-RDR

Fig. 3332

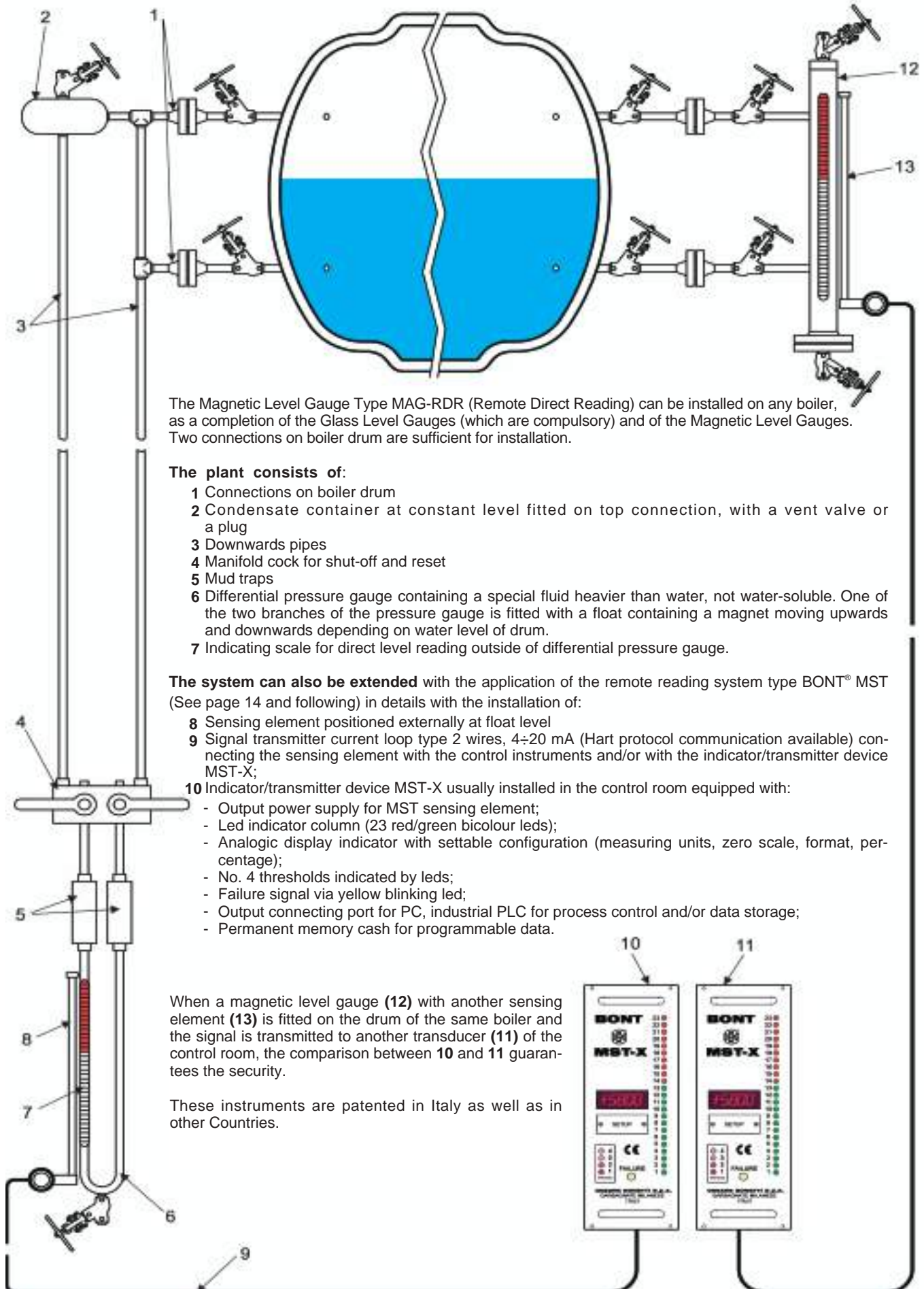

The Magnetic Level Gauge Type MAG-RDR (Remote Direct Reading) can be installed on any boiler, as a completion of the Glass Level Gauges (which are compulsory) and of the Magnetic Level Gauges. Two connections on boiler drum are sufficient for installation.

The plant consists of:

- 1 Connections on boiler drum
- 2 Condensate container at constant level fitted on top connection, with a vent valve or a plug
- 3 Downwards pipes
- 4 Manifold cock for shut-off and reset
- 5 Mud traps
- 6 Differential pressure gauge containing a special fluid heavier than water, not water-soluble. One of the two branches of the pressure gauge is fitted with a float containing a magnet moving upwards and downwards depending on water level of drum.
- 7 Indicating scale for direct level reading outside of differential pressure gauge.

The system can also be extended with the application of the remote reading system type BONT® MST (See page 14 and following) in details with the installation of:

- 8 Sensing element positioned externally at float level
- 9 Signal transmitter current loop type 2 wires, 4÷20 mA (Hart protocol communication available) connecting the sensing element with the control instruments and/or with the indicator/transmitter device MST-X;
- 10 Indicator/transmitter device MST-X usually installed in the control room equipped with:
 - Output power supply for MST sensing element;
 - Led indicator column (23 red/green bicolour leds);
 - Analogic display indicator with settable configuration (measuring units, zero scale, format, percentage);
 - No. 4 thresholds indicated by leds;
 - Failure signal via yellow blinking led;
 - Output connecting port for PC, industrial PLC for process control and/or data storage;
 - Permanent memory cash for programmable data.

When a magnetic level gauge (12) with another sensing element (13) is fitted on the drum of the same boiler and the signal is transmitted to another transducer (11) of the control room, the comparison between 10 and 11 guarantees the security.

These instruments are patented in Italy as well as in other Countries.

BONT® Magnetic Level Gauges with float immersed in vessel

The operating principle of the BONT Magnetic Level Gauges is applied also with the instrument directly immersed in the vessel. Vessel can have any form (cylindrical, parallelepiped, etc.) and be installed out of ground or under ground.

Vessel can be under atmospheric or even very high operating pressure. The working stresses of level gauge are not relevant, compared to those of vessel walls.

This instrument (Fig. 3333) includes schematically:

- a float (3333.1) immersed in vessel with an adequately long vertical extension fitted with a permanent magnet at the top end. The float is guided by a tube (3333.2) in its upwards/downwards movements according to the liquid level
- a flange (3333.3) to couple with the horizontal flange existing or to fit on vessel
- a vertical chamber (3333.4), consisting of a tube of suitable diameter and thickness fastened on flange and guiding tube. The float extension and its permanent magnet are introduced into the vertical chamber
- an indicating scale (3333.5) outside the vertical chamber, containing the bicolour small cylinders showing clearly the float and consequently the liquid level in vessel.

Accessories.

This instrument can be completed with:

- one or more magnetic switches fitted externally on the vertical chamber, or
- with the BONT Remote Reading System type MST, see page 14 and following.

Materials.

The most used materials are:

- stainless steel (different types)
- plastic materials (different types).

Generally iron, copper and silver alloys are excluded.

Enquiries and Purchase Orders.

When ordering or requesting prices, please state:

- type of fluids contained in the vessel and/or in the level gauge and their specific gravity
- vessel operating and design pressure
- vessel operating and design temperature
- position and length of displacement level to be measured
- sizes of vessel flange for level gauge connection (generally: 3 inch).

Fig. 3333

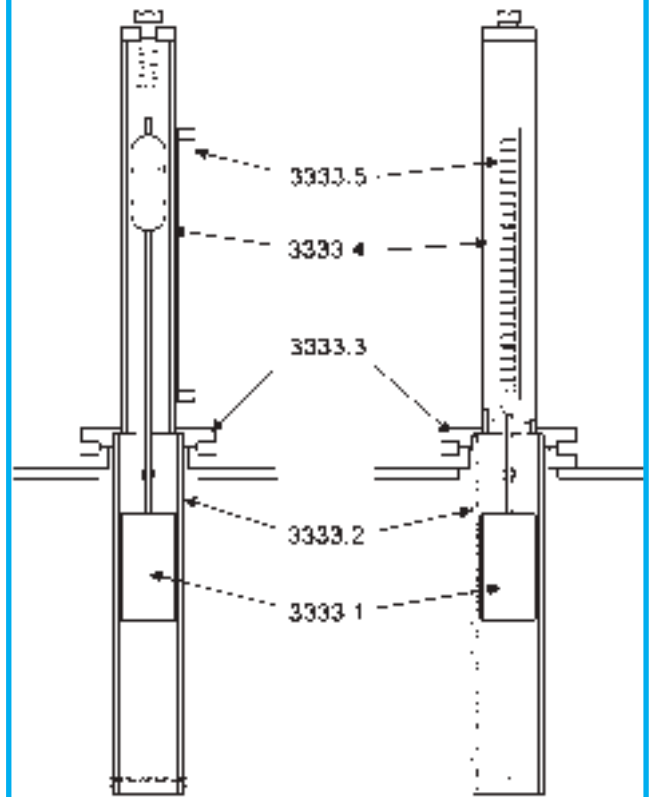

BONT® Remote Transmission System type MST and MST-X

GENERAL INFORMATION

The BONT® Remote Level Transmission System type MST (Multi Switch Transmitter) is an additional and subsidiary method for any BONT® Magnetic Level Gauge, already described in the preceding pages.

It is applicable for any operating pressure and material schedule (stainless steel, synthetic polymers, PTFE lined) even when level gauge is already installed. Note also that it is compatible with any accessory already present, as described at page 4.

This MST device can sense the position of the magnetic float, that corresponds to the level to be measured, by means of a series of very sensible magnetic sensors reed type of new generation.

A specific incorporated circuit, the transmitter, refers the sensed position by means of a transmission system with 2 wires current loop type 4÷20 mA.

This type of connection constitutes an industrial standard consistently spread and widely accepted, also for intrinsic safe applications; allows to easily connect any data acquisition and visualization system, also at very long distance through a simple couple of conductors.

The MST system can be connected to the led bar indicator device BONT® model MST-X both singularly or in parallel with any other type of industrial PLC or PC for the process control, as well as to various indicators and/or data recorders.

The application field of this system is extremely wide and can be extended to many applications, particularly on chemical and petrochemical plants and power plants.

The MST system can be installed outdoor in any weather condition, since it is not affected by heat, cold, freezing, wind.

The MST system is supplied with different feature whose differences are the measure resolution and the type of transmitter adopted.

The standard resolution is 15 millimeters, value suitable for the majority of the applications and that corresponds to the pitch between the reed sensing element; it shall be considered that the actual measure resolution for the majority of the applications is double, which means 7,5 mm thanks to the use of the sophisticated *digital resolution enhancement* technique.

On request, for special applications, will be supplied sensing elements with a pitch of 10 or 20 millimeters, which are subject to the same resolution technique (so having 5 or 10 mm resolution, due to the *digital resolution enhancement*).

The MST indicator provides different performances depending on the type of adopted transmitter that can be selected at order stage.

The available versions are:

- 1 MST-P transmitter standard type output 4÷20 mA, complete with alarm and out of scale indications;
- 2 MST-H as above with the addition of HART digital communication protocol, overlapped to the analogue 4÷20 mA signal;
- 3 MST-AE and AEH same as above with intrinsic safe protection, ATEX certified.

All these devices are complete with pre-programming functions, Signal filtering and linearization.

On request a programming kit to modify the configuration settings normally done at the workshop, is available.



The BONT® model MST-X device is a frame led bar digital indicator specifically designed to be used combined with MST transmitters.

It can both provide power supply and identify the signal from the MST level transmitter, this allows a simple electrical installation with the connections of two conductors only and use completely the simple pattern of the two wires current loop transmission system.

The shape of the housing is in conformance with the industrial standard for the rack frame system with a height of 6 units and a width of 18TE; this allows the insertion inside a panel system based on the standard 19" rack.

In any case, the possibility of front panel installation is always left, obtaining a simple rectangular slot; all cabling is realized with a practical extractable screwed connector positioned on the rear panel.

On request can be supplied a specific plastic housing to provide a supplementary protection against dust and sprays (IP65), useful when the MST-X will be installed outdoor; in this case cable glands to receive all connecting cable are prearranged.

The front panel shows a vertical line of 23 dual colour led that visualizes the level measured by the MST. The green colour led represent the liquid phase, the red colour led represent the vapour phase.

Being high brightness devices they are also visible at distance. Besides, a seven segments type red led display visualizes the level in numeric format, according to the unit of measure and the zero scale selected.

The front panel is completed by the yellow led of failure signal (for example interrupted cable or collapsed float) and a series of 4 red led that identifies the status of the programmable thresholds alarms; each led refer to a relay with exchange type contact.

The software incorporated in the microprocessor allows different functions of configuration: particularly it is possible to set precisely each thresholds alarm, to modify the unit of measure of the visualization, to set the zero at any position of the scale.

The buttons for the selection are accessible by removing a specific protective door positioned on the front panel; the programmed values are stored in a permanent memory also in absence of feeding, without the use of batteries.

A system of buffer battery, complete with regulating circuits for the continuity, is available on request to allow the visualization also in absence of power supply.

BONT® Remote Transmission System type MST and MST-X

Sensing elements type MST - Technical data

Sensing Element for external Magnetic Level Gauge, (Fig. 3335) consisting of a column of Reed Magnetic Switches and a Transmitter.

Field of application:

By means of a suitable insulation, the sensing element can be used with BONT® magnetic level gauges on services with high temperature process fluids up to 370 °C

Transmission protocol:

SMART - HART on request

Certification:

This equipment is in compliance and it is certified according to European Directive 89/336/EC; 93/68/EC; 94/9/EC (ATEX).

Sensing element (Fig. 3334.1):

- | | |
|---|--|
| Measuring range: | ● Up to 6.000 mm |
| Top extra range: | ● 50 mm |
| Bottom extra range: | ● 50 mm |
| Sensor Pitch: | ● Standard 15 mm
on request 10 or 20 mm |
| Resolution:
(digital resolution enhancement) | ● Standard 7,5 mm
on request 5 or 10 mm |
| Temperature limits: | ● -40 °C ÷ +125 °C
(uninsulated) |
| Housing: | ● SS pipe AISI 316L
Ø 16 x 1 mm IP65: |

Transmitter (Fig. 3334.2):

- | | |
|------------------------|---|
| Output signal: | ● 4÷20 mA
two wires self powered |
| Electrical connection: | ● Internal screw terminal |
| Loop power supply: | ● 11÷28 VDC |
| Response time: | ● 0,5 seconds |
| Temperature limits: | ● -20 °C ÷ +85 °C
(uninsulated) |
| Housing: | ● Aluminium IP65, explosion proof (EExd) with ¾" NPT-F cable entry (as standard) |
| Configurability: | ● Scale field, linearization, inversion, filtering, by programming kit available on request |

Sensing element for vessel internal (Fig. 3344)

We have considered the remote transmission system BONT® type MST with reading from a **sensing element (Fig. 3334.1)** fitted on a magnetic level gauge outside the vessel.

The MST system range includes also a **sensing element (Fig.3344)** to install inside a tank, composed of:

- column of Reed Magnetic Switches and a Transmitter(3344.1)
- float (3344.2) containing a permanent magnet
- tank connection flange (3344.3)
- magnet driver (3344.4)

The technical characteristics of the sensing element and of the transmitter remain unchanged (see fig. 3334).

Fig. 3334.1

Fig. 3335

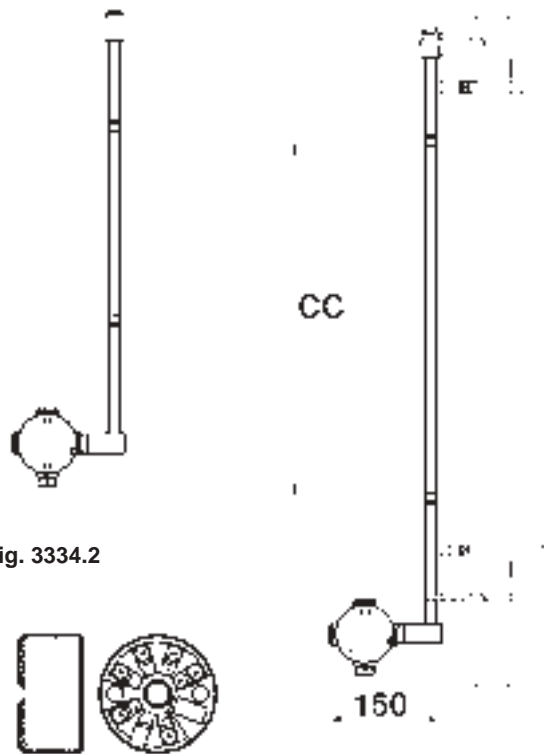
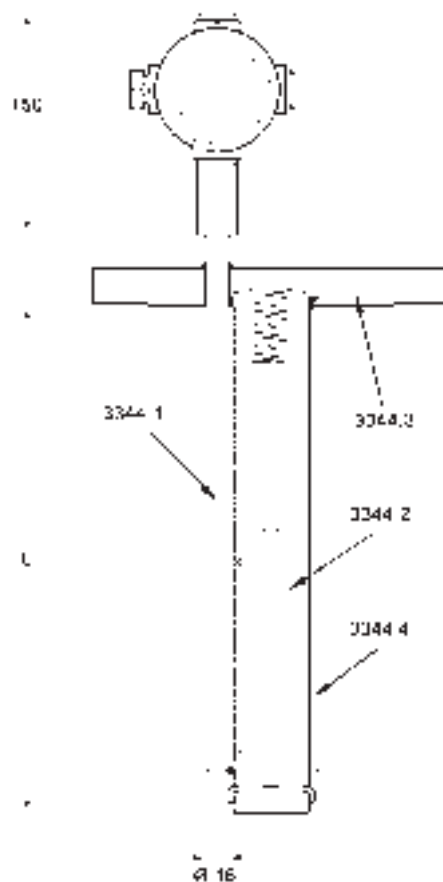

Fig. 3334.2

Fig. 3344



BONT® Remote Transmission System type MST and MST-X Indicator / Transmitter type MST-X - Technical data

Type MST-X single column bicolour led indicator

- Input signal: ● 4÷20 mA current loop which is also supplied with feed
- Electrical connections: ● Rear extractable screwed terminals
- Indication: ● Column of 23 bicolour red/green led high brightness efficiency
● Red led display with 4 digits plus one symbol
- Precision: ● Equivalent to the prescribed value for the adopted sensing element (see page 15)
- Reading of measure:
led: ● 23 red/green bright points
display: ● Double resolution respect to the adopted sensing element (*digital resolution Enhancement*) - see page 15)
- Power supply: (★) ● 18 ÷ 36 VDC or
● 24/115/230 ± 10% VAC - 50/60 Hz
- Power consumption: ● 15 W maximum
- Alarm: ● Yellow led 8 mm for failure signal
- Protection: ● IP 40 (rack design)
● IP 56 (with waterproof box with transparent cover)
● On request higher protection degree is available
- Temperature limits: ● -20 °C ÷ +85 °C
(on request -20 ÷ +115 °C)
- Housing: ● Aluminium anticorrosion anodized for rack design (approx 2 kg);
● Additional resin box for IP 56 version
- Thresholds: ● No. 4 1-exchange relay
1 A / 250 V max.

Certification:

This equipment has passed the test according to Standard EN 61326-1 + A1, and is certified compliant to European Directive 89/336/EC (Electro Magnetic Compatibility).

- (★) The system is equipped with a permanent memory that stores the programmed data, so saving them without the use of batteries also in absence of power supply.

A system of buffer battery, complete with regulating circuits for the continuity, is available on request to allow the visualization also in absence of power supply.

Fig. 3336.1

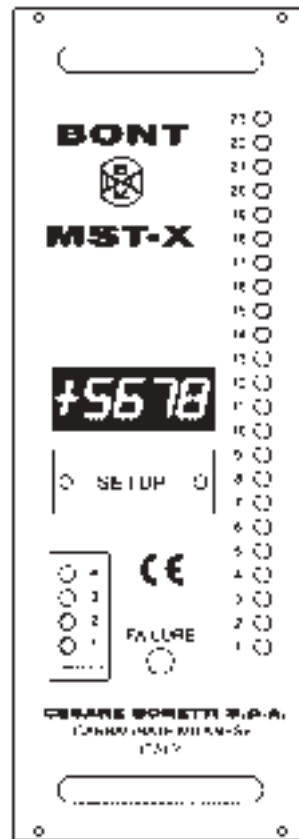
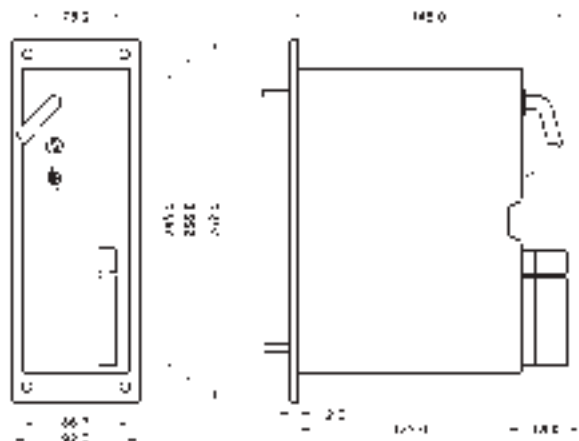

Fig. 3337.1



System RACK 19" - 6 HE - 18 TE

BONT® Remote Transmission System type MLS

As alternative of type MST System, magnetostrictive Type MLS System can be used for remote level transmission.

GENERAL INFORMATION

MLS type System is a level transmitter for continuous measurement of liquid level. It is based on the magnetostriction principle. The heart of the transmitter design is a sensing element made of appropriate magnetostrictive material contained in a protective outer pipe.

The measuring principle is a time measuring process. A low current interrogation pulse is generated in the transmitter electronics and transmitted down the magnetostrictive sensing element creating an electromagnetic field along its length. When this magnetic field interacts with the permanent magnetic field of the magnet fitted inside the float, a torsional strain of the sensing element results. This torsional strain is detected as a return pulse by the transmitter electronics. The time period between the initiation of the interrogation pulse and the detection of the return pulse is used to determine the level measurement with a high degree of accuracy and reliability. The running time of the pulse, proportional to the liquid level, is converted into an analogic 4÷20 mA output signal.

CONFIGURATION

Type MLS System is made of:

- 1 Sensor to be fixed externally at the magnetic level gauge chamber (Fig. 3348), or immersed into a tank (Fig. 3349),
- 1 Shielded 2-wire Cable which connects the transmitter to:
- 1 or more Receiver Instruments, analogic or digital, with eventual adjustable switches on the whole length.

TECHNICAL FEATURES

MATERIAL / CHARACTERISTIC

Housing of electronics	Epoxy-painted Aluminium
Sealing	IP 67; NEMA 6
Sensor outer Pipe	Stainless Steel 1.4401
(■) - Pressure max	50 bar
- Gauge Length	735 to 3785 mm with 305 mm increments
Mounting	3/4" NPT (welded for operation in Zone 0)
(■) Standard float	SST 1.4401; 52 mm diameter
-Pressure	68 mm high max 30 bar
Safety Approval	PTB Approval for § 12VbF 08/PTB Nr Ex-92.C.2128 1.Nachtrag: EEX ib II T4 Factory Mutual Intrinsic Safety Approval for Class I, Division 1, Groups C-G

MEASURING PERFORMANCE / ELECTRICAL DATA

Measured Variable	Liquid Level
Measuring Range	max 3650 mm
Output Signal	4÷20 mA
Calibration	Factory Calibration
Linearity	0.035% F.S. or 0.8 mm whichever is greater
Repeatability	0.01% F.S. or 0.38 mm
Hysteresis	0.01% F.S. or 0.38 mm
Time Constant	1 second
Input Voltage Range	10.5 to 36 Vdc
Data Transfer	2 Wires
Max Resistance	E.g. 600 ohm at 24 V
Storage Temperature	-40°C to +80°C
(●) Operating Temperature	-30°C to +70°C
Temperature Sensitivity	Zero: <0.009% per °C

(■) Applicable for Fig. 3349 only.

(●) For temperature over 70°C, please contact our Technical Department.

Fig. 3348

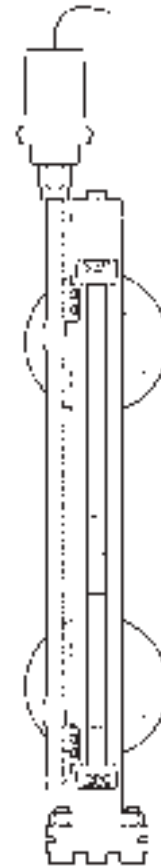
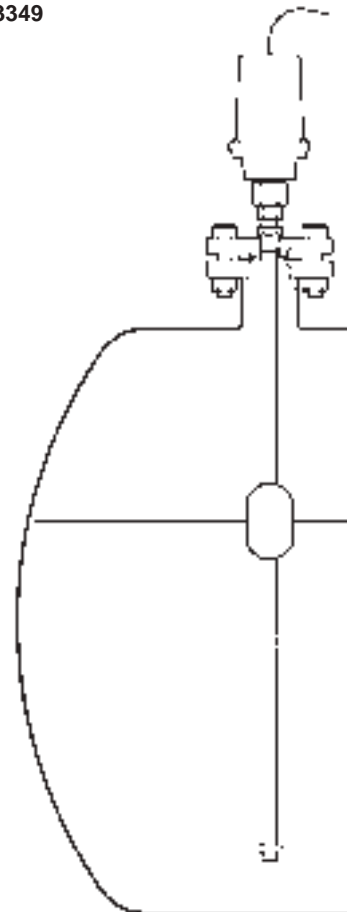

Fig. 3349



BONT® Magnetic Level Switches type MAG-LIS of Stainless Steel for PN 10/40

The Magnetic Level Switches operate according to the same operating principle as indicated on page. 3

These switches consist of:

- a vertical chamber consisting of a tube of suitable diameter and thickness containing a float wherein a permanent magnet is fixed by means of a special patented device;
The chamber is generally fixed on the vessel by only one flange sized DN 32 of 40 or 50 having a PN suitable to the application;

- a magnetic switch, fitted on the vertical chamber at the desired height.

This magnetic switch contains one or more electric contacts for opening/closing the control circuits for: top alarm, bottom alarm, pump starting, pump stopping, warning etc.

The most used switches are suitable for 0.28 A at 220 V, 60 VA; max current of contact: 1 A at 60 V. A suitable relay should be fitted for higher power supplies.

We supply different types of magnetic switches:

- monostable, bistable
- explosion proof, etc.

Choice of the suitable magnetic switch should be made according to the planned wiring diagram and safety standards of plant.

When the float is moved upwards in the gauge by the liquid flowing through the connection flange, the magnet contained in the float operates the switch.

With liquid level lowering in the vessel, the float moving downwards effects the opposite operation.

Obviously the only one verifiable level height is that where the vessel flange is positioned.

When ordering or requesting price please state:

- type of fluid contained in the level gauge and its specific gravity
- plant operating and design pressure
- plant operating and design temperature
- DN and PN of connection flange.

This Magnetic Level Switch is patented in Italy as well as in other Countries.

Fig. 3330

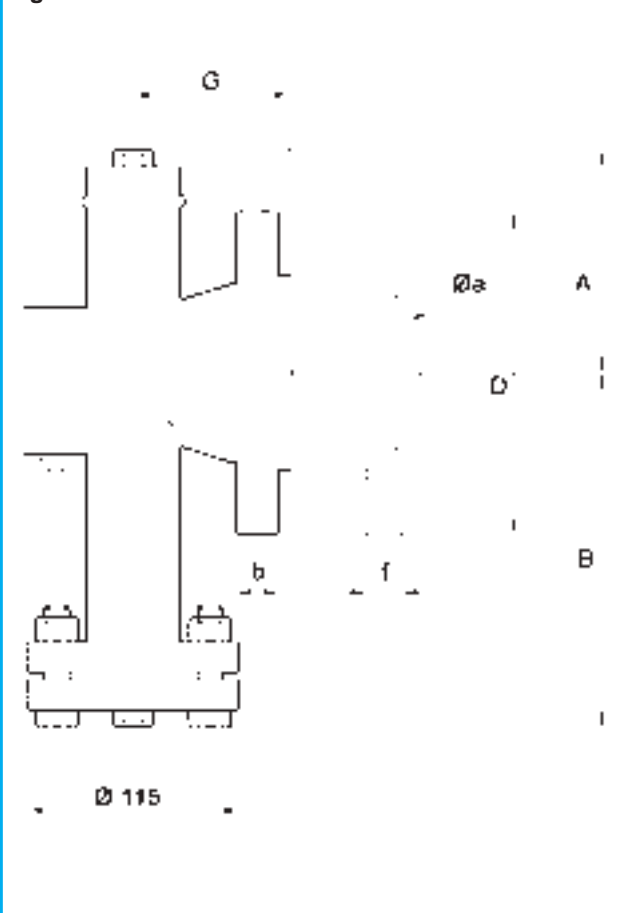



In 1905, **Cesare Bonetti** opened a shop in Milan, Italy, to manufacture small hand valves to meet the local demand. In the early 1920s, this small but growing firm, took on a new industrial look and moved into the production and sale of industrial valves.

BONETTI[®], by this time, had become a well known company for the production of piston valves sleeved-packed cocks, and glass level gauges. Subsequently, the production range, bearing the **BONT**[®] registered trademark was increased to include new valves for high temperature and high pressure service designed to meet the strictest requirements of the time and using the most advanced design and manufacturing technology. This included double sealing valves, bellows valves, diaphragm valves, and magnetic level gauges.

After two expansions, in 1969, the company moved to

its new headquarters in Garbagnate Milanese, where Bonetti continues its passion for growth through research, development and design accuracy.

This, in turn, increases its opportunities to continue to grow and expand.

Facilities:

Enclosed surface	66,000 sq.m
Offices building (with car parking below) for three stories	2,200 sq.m
Facilities building (mess-hall, locker rooms, sanitary department, etc.) for three stories	2,000 sq.m
Manufacturing shed (including Production Department and general Facilities)	19,000 sq.m



Conc. SMA 283193

This catalogue is exclusive property of Cesare Bonetti S.p.A. Any unauthorised reproduction, in total or in part, of this catalogue shall be prosecuted. Products and data sheets on this catalogue reflect current standard production. Cesare Bonetti S.p.A. reserves the right to carry out amendments to products and materials. Amendments or modifications to drawings and materials can be done also to comply with particular Customer's request or technical specifications.

A wide international sales network

Please apply for more information about our International Technical Sales Organisation



CESARE BONETTI S.p.A.

I-20024 GARBAGNATE MILANESE (Italy)
Via Cesare Bonetti 17
Telefono: +3902 990721
Telefax: +3902 9952483
Internet web site: <http://www.cesare-bonetti.it>
E-mail: bont.post@bont.it

Vendite Italia:	Telefono:	+39 02 99 072 333
	Telefax:	+39 02 99 072 300
	E-mail:	italia@bont.it
Export sales:	Telephone:	+39 02 99 072 444
	Telefax:	+39 02 99 072 400
	E-mail:	export@bont.it

Bonetti Armaturen Vertriebs GmbH
D-65549 Limburg an der Lahn (Germany)
In den Fritzenstücker, 4

Sales Office	Telephone:	+49 06431 598310
	Telefax:	+49 06431 598329
	E-mail:	bonetti-germany@t-online.de

Bonetti Australia Pty Ltd
715 Esplanade (P.O. Box 2041)
MORNINGTON - Victoria - 3931 - Australia

Sales Office	Phone & Fax:	+61 3 5977 1966
	Mobile:	+61 0412 318880
	E-mail:	dtsbont@hotmail.net.au

BONETTI (Suzhou) Level Gauges & Valves Co., Ltd.
Yuandong Gongyefang, Minsheng Road,
Shengpu District, Suzhou Industrial Park,
Jiangsu, China 215021

Sales Office	Phone	+86-512-6281 6390
	Fax:	+86-512-6281 6396
	E-mail:	bonettisuzhou@yahoo.com