

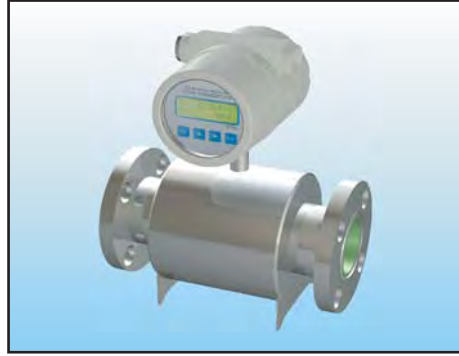

EMF-10



EMF-10



EMF-10



EMF-11



FTC[®]



전자 유량계 (Electromagnetic Flow Meters)

EMF Series

EMF-Series 모델 선택 (Model Selection Guide)

EMF - Series			
MODEL	CODE		DESCRIPTION
EMF-10	----->		Compact Version Electromagnetic
EMF-11	----->		Remote Version Electromagnetic
Connection Type	1	----->	Flange type
	2	----->	Welding type
Lining Coating Type	1	----->	ETFE(4H-4F, TEFLON), 90 °C
	2	----->	FEP, 150 °C
Electrode Material	1	----->	SUS316L
	2	----->	TANTALUM
	3	----->	TITANIUM
	4	----->	PLATINUM

[주1] 별도협의

◆ 측정 원리

원형도관에 직각으로 자속 B를 분포하면, 도관내 유체 V의 유속에 의하여 자속밀도의 직각방향으로 기전력 E_v가 유속의 세기에 비례하여 발생하는 관계식 아래와 같습니다.

$$E_v = k \cdot Bv \text{ (식1)}$$

(식1)에서 k상수는 관의 직경과 단면형태에 따라 결정됩니다. 그러므로 자속 B를 일정하게 도관에 유지하면 기전력 E_v는 유속 V에 비례한 유속신호가 나타납니다.

유속 신호 E_v에 관단면적을 대입시키면 도관의 크기에 관계가 있는 유량으로 환산되어 DC 4-20 mA의 비례 신호 유량 출력이 나옵니다. (식1)에 표시한바와 같이 유량과 신호의 관계는 자속밀도와 유속의 직접적인 관계이므로 소유량에서 대유량까지 측정이 가능합니다.

◆ Measurement Principle

The measuring principle of the electronic flow meter is based upon Faraday law that if the flow is circulated within the inside of pipe where the magnetic field is formed, the electromotive force generates at the right angle to the direction of magnetic field and flow direction, and the force is proportional to the magnetic flux density. Accordingly as the direction of flow is same as axial direction of magnetic field, the signal electromotive force, E will be exposed in the liquid generated by influence of the magnetic field. It can be formulized as follows;

$$E = K \cdot B \cdot V$$

- E : Signal Electromotive Force (V)
- B : Magnetic Flux Density (T)
- D : Inside Diameter of Measuring Pipe (m)
- V : Average Flow Speed (m/s)
- K : Proportional Factor

The faster the flowing speed of liquid is, the larger the offset of signal voltage detected from the electrode.

◆ 특징

- 전자 유량계 제어 프로그램 사용
- Self Check (자가 진단기능)
- Auto Zero Calibration (자동 영점 조절기능)
- Empty Pipe (빈관 검출기능)
- Reverse Flow Enable (정 · 역 방향 측정기능)
- Error Message (오류 표시기능)
- Free Voltage (AC85 ~ 250V)
- 노이즈 차폐 전극
- RS485 (Serial Port Printer Option)
- 간편한 설치
- 검출기와 변환기가 일체형 구조
- 좁은 공간에서도 설치 사용 가능
- 배선 구조 간편
- 변환기의 방향 (0°, 90°, 180°, 270°)
- Flange 연결 방식

◆ Features

- Measurement Type : Electromagnetic Flow meter Using Full Magnetic Flux
- 16 Bit-Microprocessor
- Real-Time data sending
- Watch-Dog function for prevention of error
- RS-232C communication function

◆ 검출기 사양 (Detection part)



Item	Description
Size	15 ~ 600mm(1/2" ~ 24")
Pipe Material	SUS304 or 316
Connection	FLANGE TYPE KS/JIS/ANSI/DIN
Linning	TEFLON (90°C)
Electrode Material	SUS316 TITANIUM (150°C)
Measuring Type	Using Full Magnetic Flux
Measuring Range	0.3 ~ 10 m/s
Accuracy	± 0.25% F.S
Temperature	-20 ~ 65 °C
Fluid Pressure	Max 20kgf/cm ²
Protection Degree	IP67 or 68
Reaction Velocity	0.1 m/s

◆ 변환기 사양 (Convertor)



Item	Description
Micro Processor	One-chip 16 Bit
Display	LCD 10 Digit x 4 Line or 20 Digit X 2 Line
Power Supply	AC 110V / 220V
Power Consumption	15VA
Output	DC 4 - 20mA ALARM : HIGH (or Low Dry contact) PULSE (Dry contact) (RS-232C)
Parameter Setting	KEY-PAD or RS-232C

◆ 측정 유량 범위 (Measuring range)

SIZE		Flux (m ³ /h)			
		Velocity	Velocity	Velocity	Velocity
(mm)	(inch)	0.3(m/s)	1 m/s	5 m/s	10 m/s
15	1/2"	0.1908	0.636	3.18	6
20	3/4"	0.33	1.136	5.654	11.309
25	1"	0.5301	1.8	8.8	17.7
32	1-1/4"	0.8685	2.9	11.5	28.9
40	1-1/2"	1.357	4.5	22.6	45.2
50	2"	2.121	7.1	35.3	70.7
65	2-1/2"	3.584	11.9	59.7	119.5
80	3"	5.429	18.1	90.5	181
100	4"	8.482	28.3	141.4	282.7
125	5"	13.25	44.2	220.9	441.8
150	6"	19.09	63.6	318.1	636.2
200	8"	33.93	113	565	1131
250	10"	53.04	177	884	1767
300	12"	76.34	254	1,272	2,545
350	14"	103.9	346	1,731	3,464
400	16"	135.7	452	2,262	4,524
450	18"	171.8	573	2,863	5,726
500	20"	212.1	707	3,534	7,069
600	24"	305.4	1,018	5,089	10,179

전자 유량계 (Electromagnetic Flow Meters)

◆ 성능곡선 (Measured error in % of reading)

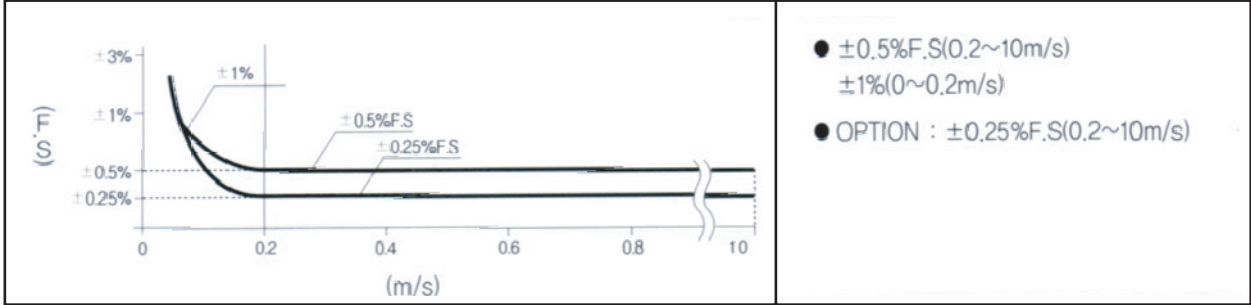

◆ 외형도 (Outline Drawing)



◆ 케이블거리 (Cable Distance)

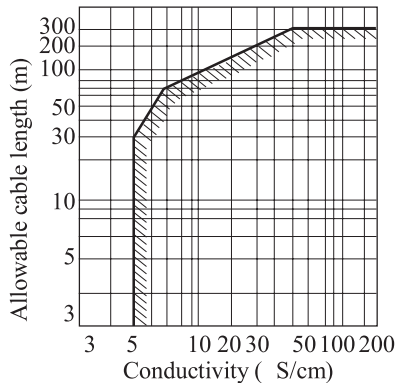

◆ 유속, 유량 환산표 (Velocity, Flux Table)

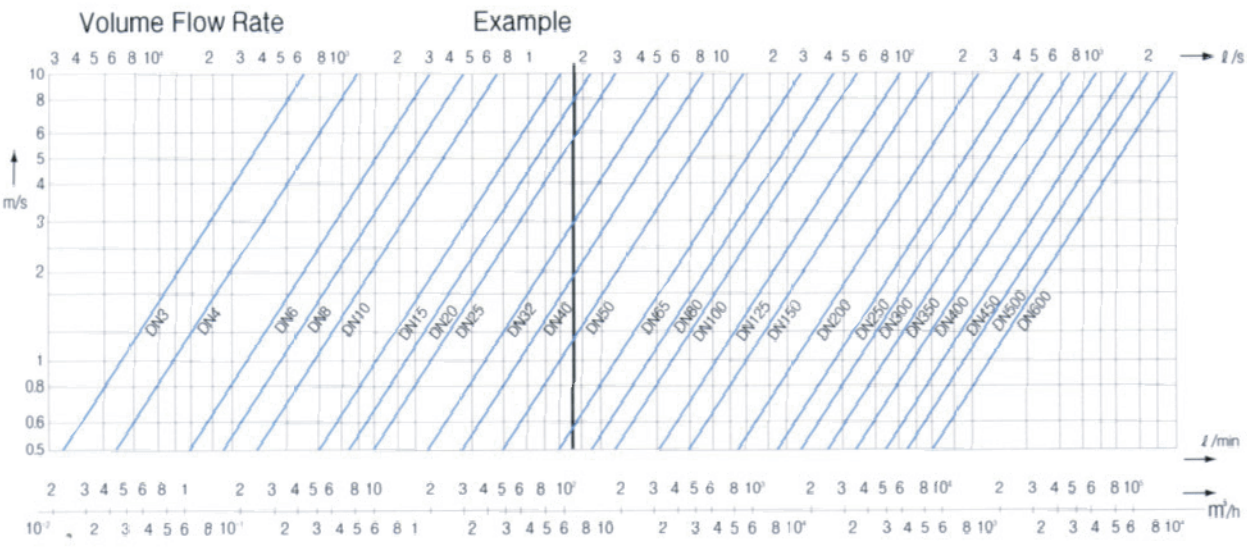

◆ 설치시 유의사항 (Installation Conditions)

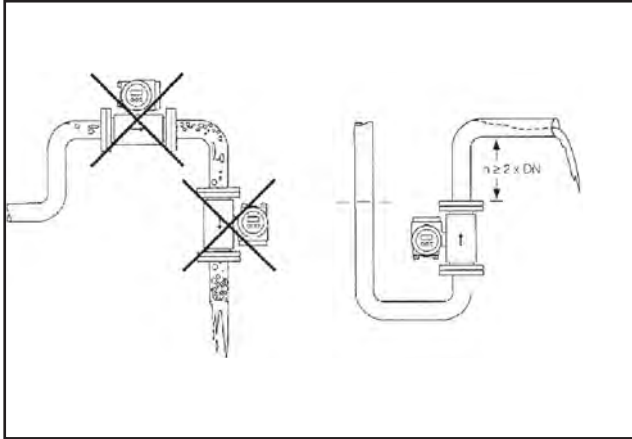

설치 위치 (The location of installation)

- 가장 윗부분에 설치하는 것은 기체 상태가 축적되므로 피해야 합니다.
- 파이프가 열린 상태로 나갈때는 최소한 그림과 같은 높이가 요구됩니다.
- Do not install the sensor on the intake side of a pump.
- This precaution is to avoid low pressure and the consequent risk of damage to the lining of the measuring.

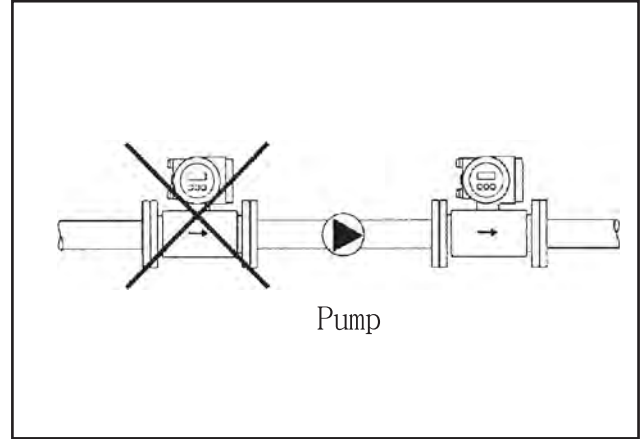

펌프의 설치 (Installation pumps)

- 펌프의 입구측에 유량계를 설치하지 말아야 합니다.
- It might be necessary to install pulse dampers in systems incorporation reciprocating, diaphragm or peristaltic pumps.

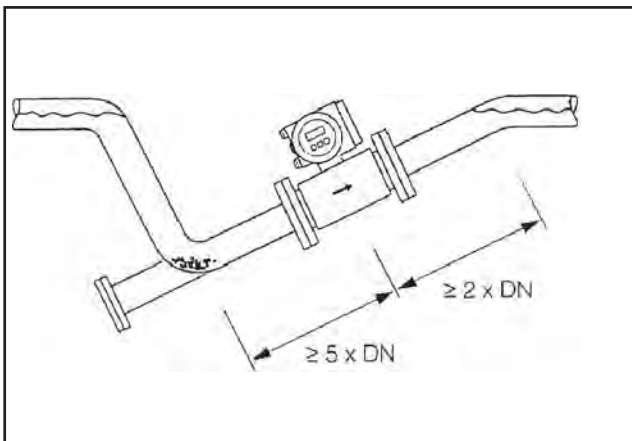

경사 파이프 (Partially filled pipes)

- 경사도를 가지고 부분적으로 채워진 파이프는 배수형 구조를 필요로 한다.
- Partially filled pipes with gradients necessitate a drain-type configuration. The Empty pipe Detection function offers additional protection by detecting empty or partially filled pipes.

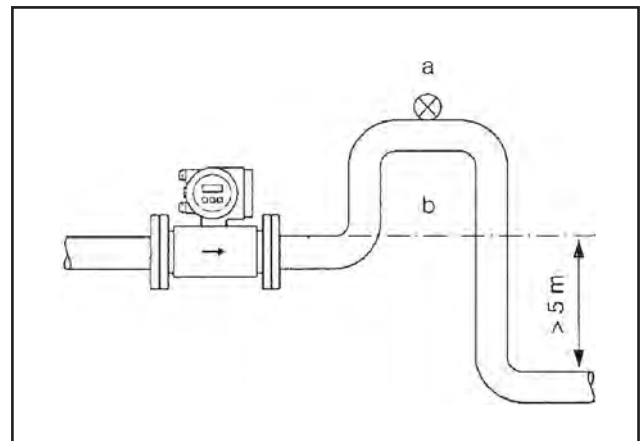

다운 파이프 (Down pipes)

- 5m 이상의 다운파이프내에 센서의 흐름에 따라 사이폰(흡수관) 또는 밴트밸브를 설치하는 것이 바람직하다.
- Install a siphon or a vent downstream of the sensor in down pipes longer than 5 meters. This precaution is to avoid low pressure and the consequent risk of damage to the lining of the measuring tube. These measures also prevent the system losing prime, which cause air inclusions.