

Inowafe

Ultrasonic level indicator type INOWAFE

Diameters corresponding to 5° beam angle.

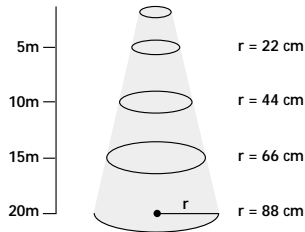

Selection

We offer the widest range of ultrasonic level measurement solutions involving standalone devices systems, sensors of different materials and with many different working frequencies.

Since the main selection aspects mentioned above (see "Measuring Range") form only part of the application know-how, please contact your local KFG distributor to assist you in selecting your optimal ultrasonic system.

Compact Transmitters

Standalone devices with transducer and transmitter in one unit.

INOWAFE

KFG's next generation of SMART compact ultrasonic level transmitters, using SenSonic™ transducer technology and KFG's latest QUEST+™ software with advanced, process adaptive digital signal processing.

The flexibility of its programming makes the INOWAFE the ideal level metering tool for basic applications requiring only a level proportional output (excl. open reservoirs) as well as for complex applications requiring linearisation, relay action, fixed target suppression (excl. agitated process tanks containing heavily fuming chemicals). INOWAFE is offered with Polypropylene or PVDF transducers as well as Teflon (PTFE) and stainless steel flush flange mounting versions.

Programming options for INOWAFE

Touch-Magnet programming (magnetic key supplied): A cost-effective solution for simple and easy applications.

The plug-in programming module: To access and program all features provided by this smart device

Remote: For remote programming and data acquisition, INOWAFE transmitters support MODBUS and HART protocol options (under development).

LEVEL - VOLUME - FLOW measurement

INOWAFE in standard form incorporates a current output and a fully programmable power relay that can be used for various alarm and control functions. Over 10 pre-programmed tank shapes for volume calculation as well as 32-point linearisation are also provided.

FLOW metering: INOWAFE can also be used as a smart flow transmitter on open channel applications with more than 20 pre-programmed flume and weir flow formulas. It also has two independent volume flow totalizers and a relay that can be used as a volume flow counter.

INOWAFE S-300

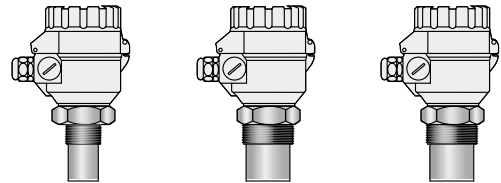

Type	ST/KB39	ST/KB38	ST/KB37
Main applic. field	Small tanks, where dead band is critical	Small process tanks with 2" process connection	
Mounting	1 1/2" BSP / NPT	2" BSP or NPT	
Frequency	80 kHz		60 kHz
Penetration through fume/vapour, foam	X		XX

X= weak; xxxx=excellent

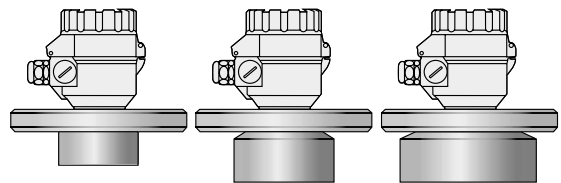

Type	ST/KB36	ST/KB34	ST/KB32
Main applic. field	Small process tanks with flanges	Medium process tanks	Medium to large process tanks
Mounting	DN 80	DN 125	DN 150
Frequency	60 kHz	40 kHz	20 kHz
Penetration through fume/vapour, foam	XX	XXX	XXXX

X= weak; xxxx=excellent

Ultrasonic level indicator type INOWAFE

The SAP-100 Plug-in Programming Module / Field Indicator

The SAP-100 module is used for programming and/or displaying measurement values. Using the SAP-100 for programming, operators can choose between menu driven "QUICKSET" or full parameter programming to access all features of this smart device, matching performance levels of Two-Part systems. In case of multi-vessel installations, using a single SAP-100 programming module, any number of INOWAFE devices can be set up. Acting as a field indicator permanently plugged into the INOWAFE, measurement values are displayed in 6-digits of selected metric or US engineering units as well as on a bargraph.

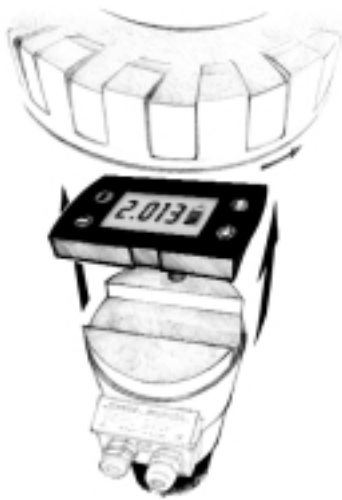

SAP-100 module

Installation

POSITION

The optimal position of the INOWAFE is between $\frac{1}{2}$ radius and $\frac{2}{3}$ diameter of the (cylindrical) tank / silo.

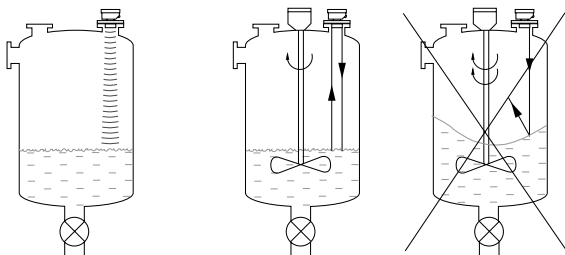

SENSOR ALIGNMENT

The sensor face has to be parallel to the surface of the liquid within $\pm 2 - 3^\circ$.

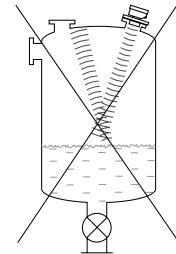

OBSTACLES

Make sure that no in-flow path or objects (e.g. cooling pipes, ladders, bracing strut, thermometers, etc) or no uneven tank wall surfaces (welding seam) protrude into the sensing cone of the ultrasonic beam.

Up to two fix objects in the tank / silo that disturb the measurement can be blocked out by the appropriate programming of the INOWAFE.

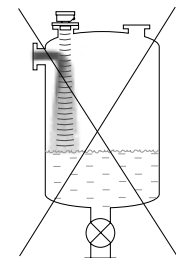

TEMPERATURE

Make sure that the transmitter will be protected against overheating by direct sunshine.

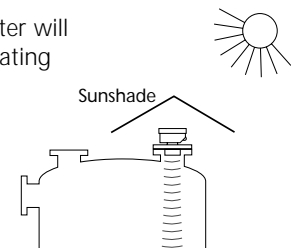

STAND-OFF PIPE FOR THE INOWAFE

The structure of the stand off pipe should be rigid, the inner rim where the ultrasonic beam leaves the pipe should be rounded.

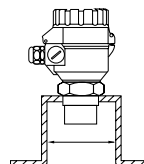

L	D _{min}		
	S _{...39}	S _{...38}	S _{...37}
150	50	60	60
200	50	60	75
250	65	65	90
300	80	75	105
350	95	85	120

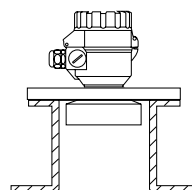

	D _{min}	
	S _{...39}	S _{...38}
90	80	*
200	80	*
350	85	*
500	90	*

*for values consult your distributor

Ultrasonic level indicator type INOWAFE

STAND-OFF PIPE FOR SENSORAR

The structure of the stand off pipe should be rigid, the inner rim where the ultrasonic beam leaves the pipe should be rounded.

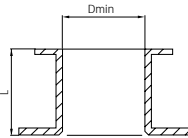

L[mm]	D _{minimum} [mm]				
	S-39	S-38/37	S-36	S-34	S-32
500	100	125	150	200	300
300	85	100	125	175	200
200	60	100	125	150	175

S-32 models with plastic transducer must not be installed in stand-off pipes since the transducer face has to protrude into the tank.

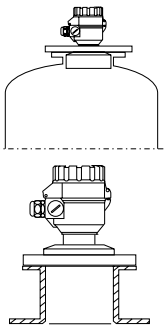

	D _{min}		
	S_ S -36_	S_ S -34_	S_ S -37_
320	80	-	-
440	-	125	-
800	-	-	150

FOAM

In case of foam above the liquid, exceeding 1-2 cm, ultrasonic devices with lower measuring frequency (40, 20 kHz) are recommended. Ideally a location should be found, where only minimal foaming occurs. Locate unit as far as possible from liquid inflow or install in a stilling pipe.

Fume/Vapour

In case of closed tanks containing chemicals or other liquids creating fumes/gases above the liquid surface, especially outdoor tanks exposed to the sun, a strong reduction of the nominal measuring range of the unit must be taken into consideration. Units with lower measuring frequency (40, 20 kHz) are recommended depending on the range.

WIND/STORM

An intensive movement of air (gas) in the vicinity of the ultrasonic cone is to be avoided. A strong wind or storm may "blow away" the ultrasound. Units with lower measuring frequency (40, 20 kHz) are recommended.

Technical Data, standalone units

INOWAFE Compact Transmitters

General Specifications

Product name	INOWAFE ST/SB-300 series
Product description	Compact type ultrasonic level transmitter
Transducer materials	Polypropylene (PP) Kynar (PVDF) / Teflon (PTFE) Stainless steel (DIN1,4571, AISI SS316Ti)
Housing material	Plastic, PBT fibre-glass reinforced, flame retardant (DuPont) Aluminium: Powder paint coated
Process temperature	PP, PVDF and PTFE versions: -30°C...+90°C Stainless steel versions: -30°C...+100°C (CIP 120°C for max. 2 hours)
Ambient temperature	-30°C...+60°C with SAP-100 progr. module -25°C...+60°C (if necessary protect the device from over heating by direct sunshine)
Pressure (absoloute)	0,3...3 bar (0,03...0,3MPa) Stainless steel versions 0,9...1,1 bar (0,09...0,11MPa)
Seals	PP transducer:EPDM All other transducer versions FKM (Viton)
Mechanical protection	Sensor: IP68 (submersible) Housing: IP67 (Nema 6)
Power supply / Consumption	High voltage versions: 85...255V AC / 6VA Low voltage versions: 10,5...40V DC / 3,6W, 10,5...28V AC / 4VA
Accuracy*	±(0,2% of measured distance +0,05% of range)
Resolution	Depending on distance to be measured < 2m: 1mm, 2...5m: 2mm, 5...10m: 5mm, >10m:10mm
Outputs	Analogue:4/20 mA, 600 Ohm, galvanically isolated, secondary lightning protection Contact: SPDT (NO/NC); 250V AC, 3A Interface: RS 485 (optional) HART (optional) Display (SAP-100): 6 Digits, icons and bargraph, Custom LCD
Electrical connections	2 x PG16 or 2 x 1/2" NPT wire cross section: 0,5...2,5mm ²
Electrical protection	Class I. with aluminium housing and Class II. with plastic housing

Ultrasonic level indicator type INOWAFE

Special Data of INOWAFE for liquids with PP, PVDF and PTFE transducers

Type	PP / PVDF transducers
	ST □ - 3 9 □ - □
	SB □ - 3 9 □ - □
	PTFE transducers
	STT - 3 9 □ - □
	SBT - 3 9 □ - □

Transducer materials PP, PVDF or PTFE
 Maximum measuring distance* (m / ft) 4 / 13 (PP / PVDF)
 3 / 10 (PTFE)

Min. measuring distance* (dead band) (m / ft) 0,2 / 0,65

Total beam angle (-3dB) 6°

Measuring frequency 80 kHz

Process connection 1 1/2" thread

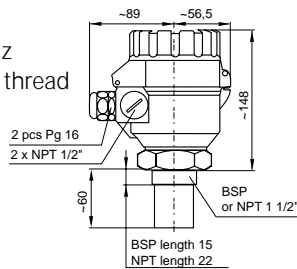

Type	PP / PVDF transducers
	ST □ - 3 8 □ - □
	SB □ - 3 8 □ - □
	PTFE transducers
	STT - 3 8 □ - □
	SBT - 3 8 □ - □

Transducer materials PP, PVDF or PTFE
 Maximum measuring distance* (m / ft) 6 / 20 (PP / PVDF)
 5 / 16 (PTFE)

Min. measuring distance* (dead band) (m / ft) 0,25 / 0,82

Total beam angle (-3dB) 5°

Measuring frequency 80 kHz

Process connection 2" thread

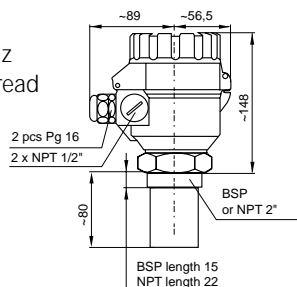

Type	PP / PVDF transducers
	ST □ - 3 7 □ - □
	SB □ - 3 7 □ - □
	PTFE transducers
	STT - 3 7 □ - □
	SBT - 3 7 □ - □

Transducer materials PP, PVDF or PTFE
 Maximum measuring distance* (m / ft) 8 / 26 (PP / PVDF)
 6 / 20 (PTFE)

Min. measuring distance* (dead band) (m / ft) 0,35 / 1,2

Total beam angle (-3dB) 7°

Measuring frequency 50 kHz

Process connection 2" thread

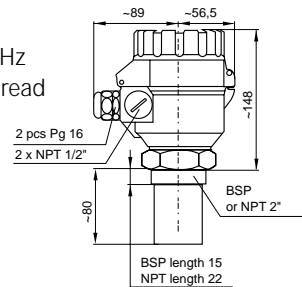

Type	PP / PVDF transducers
	ST □ - 3 6 □ - □
	SB □ - 3 6 □ - □

Transducer materials PP or PVDF
 Maximum measuring distance* (m / ft) 10 / 33

Min. measuring distance* (dead band) (m / ft) 0,35 / 1,2

Total beam angle (-3dB) 5°

Measuring frequency 60 kHz

Process connection Flange

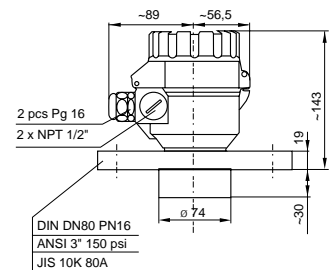

Ultrasonic level indicator type INOWAFE

Special Data of INOWAFE for liquids with PP and PVDF transducers

Type	PP / PVDF transducers
	ST □ - 3 4 □ - □
	SB □ - 3 4 □ - □
Transducer materials	PP or PVDF
Maximum measuring distance* (m / ft)	15 / 49
Min. measuring distance* (dead band) (m / ft)	0,45 / 1,5
Total beam angle (-3dB)	5°
Measuring frequency	40 kHz
Process connection	Flange

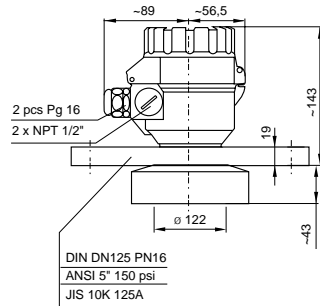

Type	PP / PVDF transducers
	ST □ - 3 2 □ - □
	SB □ - 3 2 □ - □
Transducer materials	PP or PVDF
Maximum measuring distance* (m / ft)	25 / 82
Min. measuring distance* (dead band) (m / ft)	0,6 / 2
Total beam angle (-3dB)	7°
Measuring frequency	20 kHz
Process connection	Flange

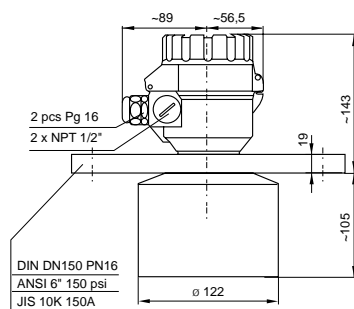

Special Data of INOWAFE for liquids with PTFE and Stainless Steel transducers

Type	PTFE st.st. transducers
	STS - 3 6 □ - □
	SBS - 3 6 □ - □
Transducer materials	stainless steel
Maximum measuring distance* (m / ft)	7 / 23
Min. measuring distance* (dead band) (m / ft)	0,4 / 1,3
Total beam angle (-3dB)	5°
Measuring frequency	60 kHz
Process connection	Flush flange

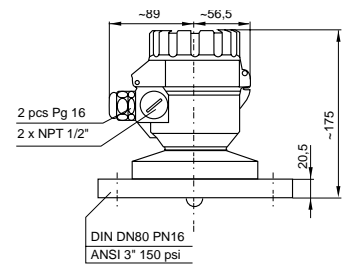

Type	PTFE st.st. transducers
	STS - 3 4 □ - □
	SBS - 3 4 □ - □
Transducer materials	stainless steel
Maximum measuring distance* (m / ft)	12 / 39
Min. measuring distance* (dead band) (m / ft)	0,55 / 1,8
Total beam angle (-3dB)	5°
Measuring frequency	40 kHz
Process connection	Flush flange

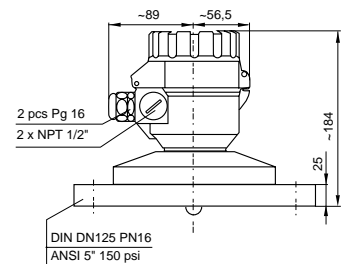

Ultrasonic level indicator type INOWAVE

Type PTFE st.st. transducers
S T S - 3 2 □ - □
S B S - 3 2 □ - □

Transducer materials stainless steel
 Maximum measuring distance* (m / ft) 15 / 49
 Min. measuring distance* (dead band) (m / ft) 0,65 / 2,2
 Total beam angle (-3dB) 7°
 Measuring frequency 20 kHz
 Process connection Flush flange

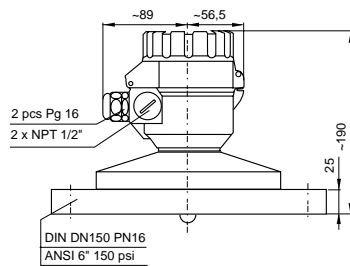

Type SAP-100 programming module

Field indication 6 digits, icons and bargraph,
 Custom LCD
 Ambient temperature -25°C...+60°C
 Housing material PBT fibre-glass reinforced plastic,
 flame retardant (DuPont®)

TYPE CODE KEY

INOWAVE S □ □ - 3 □ □ - □

Type	Code	Housing	Code	Range	Code	Mounting	Code	Supply & Output	Code
Transmitter	T	PP / ALU	A	25 Meter	2	BSP Thread	0	85...265V AC	
with indicator	B	PVDF / ALU	B	15 Meter	4	NPT Thread	N	4...20mA + Relay	1
		PTFE / ALU	T	10 Meter	6	DN 80	2	4...20mA + Hart + Relay	3
		St. St. / ALU	S	8 Meter	7	DN 100	3	RS 485 + Relay	5
		PP / Plastic	P	6 Meter	8	DN 125	4	10,5...40V DC	
		PVDF / Plastic	V	4 Meter	9	DN 150	5	4...20mA + Relay	2
		PTFE / Plastic	F			DN 200	6	4...20mA + Hart + Relay	4
		St. St. / Plastic	M					RS 485 + Relay	6